

# 2018+ Ford F-150 5.0L ROUSHcharger Kit

Installation Instructions  
P/N: 422095 (R1 1 18-6006P1)  
EO D-418-33



**FORD PERFORMANCE  
PARTS**



**ROUSH**  
PERFORMANCE

12170 GLOBE STREET LIVONIA, MI 48150 | 800.59.ROUSH

# 2018+ Ford F-150 5.0L ROUSHcharger Kit

Installation Instructions

P/N: 422095 (R1 1 18-6006P1)

EO D-418-33



## Application:

2018+ Ford F-150 with 5.0L 4-Valve Engine and Automatic Transmission.

## Important Notes:

- Before installing your F-150 ROUSHcharger Kit, please read the installation manual and verify that all items are present. If you are missing hardware or have any questions, please contact ROUSH Performance at 1-(800) 59-ROUSH.
- Premium fuel (91 octane or higher) is required to prevent “spark-knock” or detonation under certain operating conditions.
- Once this modification has been completed this vehicle is no longer capable of running E85 (it is no longer a flex-fuel vehicle).
- Operating your engine without the Roush PCM recalibration will result in engine damage or failure and will void your warranty.
- The use of fuel additives (i.e. octane boosters) is not recommended. There is a possibility that these chemicals can damage your engine and cause driveability issues with your vehicle.



**Table of Contents**

Packing List for 422095 (R1118-6006P1) ROUSHcharger Kit ..... 3

Equipment and Supplies Required..... 6

Glossary of Terms..... 6

Information About the Supercharger Bypass Operation ..... 6

Important Information Regarding Supercharger Noise ..... 7

Limit of Liability Statement..... 7

Safety Precautions ..... 7

Section A – Disassembly..... 8

Section B – Modifications ..... 17

A/C Compressor Pulley Replacement..... 17

Crankshaft Pulley Replacement ..... 18

Transmission Cooler Line Bracket Bolt Removal ..... 19

Brake Booster Hose and Aspirator Assembly Modification ..... 21

A/C Line Modification..... 23

Front Cover Modification..... 24

Intercooler Pump Harness Procedure ..... 26

MAF-to-MAP Harness..... 29

Changing the Factory Spark Plugs ..... 33

Section C – Subassembly ..... 36

Air Box Assembly ..... 36

Clean Air Tube Assembly ..... 37

Intercooler Low Temperature Radiator (LTR)..... 38

Intake Manifold Build Up..... 40

Supercharger Build Up..... 40

Fuel Rail Assembly ..... 41

Intercooler Hard Line Assembly ..... 43

Section D – Installation..... 44

Intake Manifold and Fuel Rails ..... 44

Upper FEAD Bracket..... 47

Supercharger..... 48

PCV Purge Hose..... 51

Lower FEAD Assembly..... 52

Intercooler Reservoir Mounting ..... 54

Intercooler Radiator Assembly Mounting..... 56

Intercooler Pump Mounting..... 57

Coolant Hoses..... 58

Air Induction System ..... 60

Section E – Front Bumper Cover Removal..... 62

Section F – Final Assembly ..... 63

PCM Flashing..... 64

Appendix A – Hydrocarbon Trap Relocation ..... 65

**2018+ Ford F-150 5.0L ROUSHcharger Kit**

**PACKING LIST FOR 422095 (R1118-6006P1) ROUSHCHARGER KIT**

| Description   | Part Number       | Quantity |
|---|-------------------|----------|
| <b>Air Induction</b>  |                   |          |
| Airbox Tray   | 1115-9A612        | 1        |
| Upper Airbox Cover Assembly   | 1118-9643HC       | 1        |
| MAF Tube  | 111550-12B579     | 1        |
| Air filter - Dry  | 131550-9601R      | 1        |
| Tube, Clean Air -   | 1118SC-9B660      | 1        |
| Hardware Kit Air Induction  | 1118-TVSHWKA      | 1        |
| Coupler - MAF to CAT  | 1115SC-9B661      | 1        |
| Coupler - T-body to CAT   | 1118SC-9B662      | 1        |
| Grommet - 5/8" ID   | 1150-58GRMT       | 2        |
| Fitting, 5/8" PCV Fresh Air   | 1311-9N285        | 1        |
| Fitting, 3/8" PCV   | KLR-9N285         | 1        |
| Clamp, 90-110 mm-12 mm, Stainless Steel Band                          | 1368016100        | 2        |
| Hose Clamp  | R07130015-13      | 2        |
| Screw, Self-Tapping M6 x 25 mm  | W506976-S437      | 6        |
| Push Nut- ROUND NO. 10 (Hydrocarbon Trap Retention)                   | 94800A816         | 4        |
| Bolt - MAF Tube to Airbox (M8 x 1.25 x 25)                            | W500224-S437      | 2        |
| <b>Intake Manifold Hardware</b>                                       |                   |          |
| Fuel Charging Assembly  | 1318-9H487        | 1        |
| Supercharger Assembly with 80 mm Pulley (FIFD)                        | 1318-6F066        | 1        |
| Intake Components   | 1318-KIT2         | 1        |
| Fuel Rail Assembly  | 1318-9F792        | 1        |
| Throttle Body - 87mm single bore (KR3Z-9E926-A)                       | M-9926-M50BRSH    | 1        |
| Fuel Injector Kit (Set of 8)  | 13119F593K        | 1        |
| Spark Plug (Pack of 8)  | M-12405-M50A      | 1        |
| Hardware Kit Fuel Charging  | 1118-TVSHWKB      | 1        |
| Bolt, M8 x 1.25 x 35 Pan Head - Knock Sensor                          | 92095A292         | 4        |
| Bolt, M8 x 40 (Supercharger to Upper Intake)                          | 161826            | 8        |
| Bolt - M6 x 1 x 20 Fuel Rail to Upper Intake                          | BM6X100X20HF-S437 | 1        |
| Bolt M6 x 1 x 45 (Fuel Rail to Cylinder Head)                         | 161817            | 5        |
| Gasket, T-Body  | 1318-9E936        | 1        |
| Bolt, M6 x 1.00 x 40 Hex Flange S439 Coating (Upper to Cylinder Head) | R18020004-00-S439 | 6        |
| Bolt, M6 x 35.5 Hex Head Flange and Washer                            | N808429-S437      | 2        |
| Bolt - M6 x 1 x 24 (SIP to front cover)                               | N807309-S437      | 1        |
| <b>FEAD</b>   |                   |          |
| Hardware Kit FEAD   | 1318-TVSHWKC      | 1        |
| Pulley - 6K Grooved Idler - 77 mm                                     | 900162            | 1        |
| Pulley - Idler Smooth 70 mm   | 34-0284           | 2        |
| Idler Pulley Post   | 1318-8B653P       | 1        |
| Bolt - M8x1.25x70 Flange Bolt   | 11116112          | 1        |
| Bolt - Upper FEAD-to-Intake (M8x50)                                   | W500313-S437      | 1        |
| Bolt - Idler (M8x1.25x28_large washer) (N808102)                      | R18020060-00      | 2        |

| Description  | Part Number    | Quantity |
|--|----------------|----------|
| Bolt - Upper Bracket-to-Engine (M8x1.25x60)        | 11116346       | 4        |
| Bolt - Lower Bracket-to-Engine (M8x1.25x120)       | N811329-S437   | 2        |
| FEAD Components                                    | 1318-KIT3      | 1        |
| FEAD Bracket - Upper                               | 1318-8B653U    | 1        |
| FEAD Tensioner Bracket Assembly                    | 1318-8B653     | 1        |
| Serpentine FEAD Belt - 1st Sheave 6K               | K060806        | 1        |
| 2018 5.0L Crank Damper                             | JR3Z-6312-A    | 1        |
| 2018 F-150 AC Compressor Clutch/Pulley Assembly    | 1120-68319162  | 1        |
| Bolt, Crank Damper                                 | BR3Z-6A340-A   | 1        |
| <b>PCV and Vacuum</b>                              |                |          |
| Hardware Kit PCV                                   | 1118-TVSHWKD   | 1        |
| 3/8" Hose - BEVIS 15.5 inch                        | 27004          | 1        |
| Hose - Supercharger Bypass to Supercharger         | 1318-9E498     | 1        |
| Cap, 3/8 VMV Outlet Vacuum                         | CS2575         | 1        |
| Clamps - Worm Drive (BEVIS Hose)                   | 62003          | 1        |
| Clamps - 5/8" Hoses (Constant Tension)             | 7329K11        | 4        |
| Brake Aspirator Hose                               | 1115-9D691     | 1        |
| 75 mm x 43 mm Foam Pad, Single-Sided V710 Material | M19-013-0066   | 1        |
| Screw, M6 x 1.0 Hex                                | W500214-S437   | 1        |
| J-Clip, M6 x 1.0 (Degas Bottle)                    | N623332-S439   | 1        |
| Bolt, M8 x 1.25 x 20 mm                            | 90386A108      | 4        |
| <b>Wiring</b>                                      |                |          |
| Wiring Hardware Kit                                | 1120-TVSHWKE   | 1        |
| Electrical Jumper - I/C Pump                       | 1320-8W501     | 1        |
| MAF to MAP   | 1318-12B579W   | 1        |
| Nut - I/C Relay Mounting (M6x1.0)                  | W520412-S437   | 1        |
| Pack of Zip Ties (25)                              | ZIP-TIE-KIT    | 1        |
| <b>Decals/Labels/Instructions</b>                  |                |          |
| Hardware Kit Paperwork                             | 1118-TVSHWKF   | 1        |
| Supercharger Badge                                 | 1318-6F066BDG  | 1        |
| Decal - Premium Fuel Only (Fuel Door)              | 13109A095      | 1        |
| Decal - 2018 Belt Routing and Vacuum               | 1318-6E072     | 1        |
| Decal - Premium Fuel Only (Cluster)                | R07110004-11   | 1        |
| Decal - PCM  | R07100008-10   | 1        |
| RDT Voucher Card - F150 Federal States             | P1118-P1       | 1        |
| Fuel Filler Cover - Premium Fuel Only              | 1116-9034      | 1        |
| Fuel Filler Cover - Die Cut Tape Double-sided      | 1116-9033      | 1        |
| Sticker 5W-50                                      | 1318-5W50ST    | 1        |
| Limited Powertrain Warranty                        | 336PTW         | 1        |
| EO Label - 18+ Mustang and F150 SC                 | D41833-9A095EO | 1        |

| Description  | Part Number    | Quantity |
|--|----------------|----------|
| <b>Intercooler System - Tubes, Hoses and Clamps</b>    |                |          |
| Kit 4 Intercooler                                      | 1118-KIT4      | 1        |
| Hose, 3/4" Intercooler Reservoir Inlet                 | 1118-8D031     | 1        |
| Hose Assembly, 3/4" Intercooler Pump Inlet             | 1115-8D029     | 1        |
| Hose Assembly, 3/4" Low Temp Rad Outlet                | 1118-8D030     | 1        |
| Hose Assembly, 3/4" Intercooler Pump to LTR            | 1115-8K236     | 1        |
| 3/4" Hose Assembly Jumper                              | 1318-8D032     | 2        |
| PCV Purge Hose with Bubbler - Valve to Spacer          | 1318-6K817     | 1        |
| Brake Aspirator-to-Throttle Body                       | 1115-9D692     | 1        |
| CAC Hard Line Assembly                                 | 1318-8D028     | 1        |
| Electric Water Pump I/C, Without Brackets (0392024058) | 1318-8501      | 1        |
| Reservoir, Mustang/F150 Supercharger Degas             | 1115-8D028     | 1        |
| Low Temp Radiator - Air Deflector                      | 1115-5K235     | 1        |
| Low Temperature Radiator Assembly                      | 1115-8K229     | 1        |
| Spanner Bracket, LTR Mounting                          | 1115-8K241     | 1        |
| <b>Intercooler System - Miscellaneous</b>              |                |          |
| Hardware Kit Intercooler 1.0                           | 1118-TVSHWKG   | 1        |
| Clamps - 3/4" Hoses (Constant Tension)                 | CT19x12-BO     | 8        |
| Power Grip 3/4"  | 32929          | 2        |
| Screw, M6 x 1.0 x 20                                   | W500214-S437   | 6        |
| Nut, M6 x 1.0 Hex                                      | W520412-S437   | 2        |
| J-Clip, M6 x 1.0 (Degas Bottle)                        | N623332-S439   | 1        |
| Bolt, M8 x 1.25 x 29 (MAF Tube to Air Box)             | W500224-S437   | 2        |
| Bolt, M8 x 33  | N808920-S437   | 4        |
| J-Clip, M8 x 1.25                                      | W520823-S439   | 2        |
| Grommet (Rubber Grommet LTR Isolator)                  | R07060107-13   | 4        |
| Steel Grommet Insert                                   | R07060108-13   | 4        |
| Hardware Kit Intercooler 2.0                           | 1118-TVSHWKH   | 1        |
| Foam - LTR to Shroud 39"                               | 1115-8K229FOAM | 1        |
| Bracket - LTR Lower LH                                 | 1118-8K242     | 1        |
| Bracket - LTR Lower RH                                 | 1118-8K243     | 1        |
| Degas Bottle Cap                                       | 9C3Z-8101-B    | 1        |
| Bracket - Degas Bottle to Fan Shroud                   | 1115-6B634     | 1        |
| Bracket, Inter Cooler Pump Mounting                    | 1118-8C4191    | 1        |
| Intercooler Pump Bracket                               | 1118-8C4192    | 1        |

**If you are missing any items, please call us toll free at 1-800-59-ROUSH.**

**EQUIPMENT AND SUPPLIES REQUIRED**

- Cordless Impact Wrench
- 1/4" and 3/8" Drive Ratchets with Extensions
- Metric and Standard Socket Sets (short and deep recommended)
- 1/2" Drive Ratchet or Breaker Bar
- Metric and Standard Wrench Sets
- 3/8" Drive Torque Wrench (7-35 ft-lb range)
- Short Phillips-head Screwdriver
- 5/8" Fuel Line Removal Tool
- T-20 Torx Bit Screwdriver or Socket
- 5/16" Drill Bits and Drill Motor
- Grinder/Cutoff Wheel (Angle Grinder/Dremel)
- Coolant (meeting Factory Ford specification for 2011+ F-150)
- 6" Scale, Tape Measure, or Other Measuring Device
- Assembly Lubricant (White Lithium Grease or Petroleum Jelly)
- Electrical Tape
- Sharp Knife or Razor Blade
- Trim Tool
- Trim Pad Tool (for pushpin removal)
- Hammer (Mini-Sledge)
- Fender Cover (2)
- Medium Strength Thread Locker - Loctite 242 (Blue) or equivalent
- Rust Preventative
- Isopropyl Alcohol

**GLOSSARY OF TERMS**

|                |   |
|----------------|---|
| ACT            | Air Charge Temperature Sensor (From the factory, this function is integrated into the MAF sensor. With this kit, a separate ACT sensor is installed into the intake manifold) |
| ETC            | Electronic Throttle Control   |
| IMRC           | Intake Manifold Runner Control  |
| MAFS           | Mass Air Flow Sensor  |
| PCM            | Powertrain Control Module (a.k.a. ECM, ECU, PCU, EEC)   |
| PCV            | Positive Crankcase Ventilation  |
| T-MAP          | Manifold Absolute Pressure and Temperature Sensor   |
| TPS            | Throttle Position Sensor  |
| RDT            | ROUSH Diagnostic Tool   |
| SIP            | Supercharger Inlet Pressure   |
| VMV            | Vapor Management Valve (aka Canister Purge Valve)   |
| Breakout Point | A place in an electrical harness where the wiring for an individual component leaves (breaks out of) the main harness to attach to an individual component.                   |

**INFORMATION ABOUT THE SUPERCHARGER BYPASS OPERATION**

There is a great deal of misinformation about the function of supercharger bypass systems. The supercharger is a positive-displacement pump; that is, so long as it is rotating, it is always pumping air. During low demand or high vacuum operation (i.e. idle, deceleration, and light throttle cruise), the pumping action is undesirable as it creates unwanted heat and noise. The bypass circuit, when open, prevents any pressure buildup across the supercharger and allows air to circulate through the rotors, allowing the supercharger to "idle" freely during these conditions. This results in reduced noise, and by reducing heat buildup in the intake, significantly improves street and strip performance. As throttle demand increases, the bypass circuit is closed, resulting in full performance from the supercharger. The bypass circuit is never used to limit or control boost during full-throttle operation and defeating or altering the bypass function will not result in improved performance in any condition, and will result in poor driveability.

## **IMPORTANT INFORMATION REGARDING SUPERCHARGER NOISE**

We understand that you may notice some noise variations from your supercharger. The majority of noises are completely normal and each supercharger can have a different noise signature. As superchargers are belt-driven by the engine, the engine's torsional vibrations will cause the mechanical components of the supercharger, including gears, shafts, and bearings, to make noise. Noise levels can also be influenced by both the supercharger and ambient air temperatures, especially in cold environments. As temperatures and engine speeds vary, the characteristics of the noise may change. It's important to note that each unit may produce slightly different sounds due to these variables. Generally speaking, these noises do not affect the performance, reliability, or longevity of your supercharger and are not cause for concern. If you have any concerns, please feel free to reach out to our team.

## **LIMIT OF LIABILITY STATEMENT**

The information contained in this publication was accurate and in effect at the time the publication was approved for printing and is subject to change without notice or liability. ROUSH Performance Parts reserves the right to revise the information presented herein or to discontinue the production of parts described at any time.

## **SAFETY PRECAUTIONS**



### **CAREFULLY READ THE IMPORTANT SAFETY PRECAUTIONS and WARNINGS BEFORE PROCEEDING WITH THE INSTALLATION!**

Appropriate disassembly, assembly methods and procedures are essential to ensure the personal safety of the individual performing the kit installation. Improper installation due to the failure to correctly follow these instructions could cause personal injury or death. Read each step of the installation manual carefully before starting the installation.

- Always wear safety glasses for eye protection.
- Place the ignition switch in the OFF position.
- Always apply the parking brake when working on the vehicle.
- Block the front and rear tire surfaces to prevent unexpected vehicle movement.
- Operate the engine only in well-ventilated areas to avoid exposure to carbon monoxide.
- Do not smoke or use flammable items near or around the fuel system.
- Use chemicals and cleaners only in well-ventilated areas.
- Batteries can produce explosive hydrogen gas which can cause personal injury. Do not allow flames, sparks or flammable sources to come near the battery.
- Keep hands and any other objects away from the radiator fan blades.
- Keep yourself and your clothing away from moving parts when the engine is running.
- Do not wear loose clothing or jewelry that can be caught in rotating or moving parts.



### SECTION A - DISASSEMBLY

The following section will guide you through the disassembly of the stock components. Special care should be taken to label fasteners and parts that are taken off during this procedure since many will be reused:

1. Cover both fenders with fender covers to protect the vehicle finish.
2. Release the fuel system pressure.

**NOTE:** The following procedure is taken directly from the Ford Service Manual.

#### **⚠ WARNING**

**Fuel in the fuel system remains under high pressure even when the engine is not running. Before working on or disconnecting any of the fuel lines or fuel system components, the fuel system pressure must be relieved. Failure to do so can result in personal injury.**

#### **⚠ WARNING**

**Do not smoke or carry lighted tobacco or open flame of any type when working on or near any fuel-related components. Highly flammable mixtures are always present and can be ignited, resulting in personal injury.**

- a. Disconnect the fuel pump control module electrical connector. It is located on the frame rail above the spare tire.

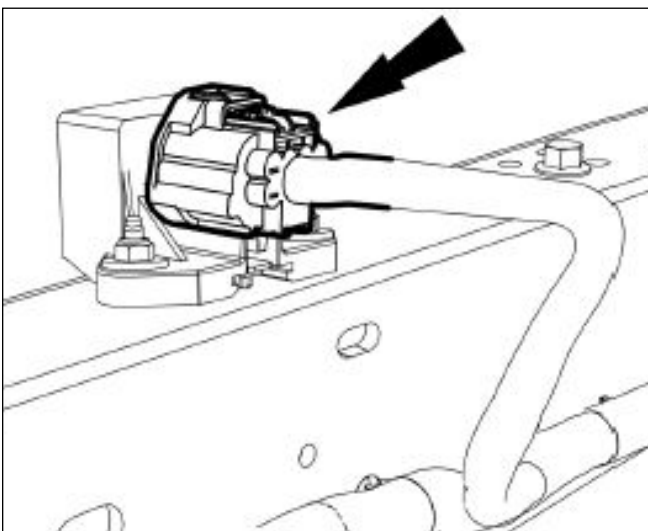

- b. Start the engine and allow it to idle until it stalls.

- c. After the engine stalls, crank the engine for approximately 5 seconds to make sure the fuel rail pressure has been released.
  - d. Turn the ignition switch to the OFF position.
3. Using an 8 mm wrench, disconnect the (-) negative and (+) positive connections to the battery and remove the battery from the vehicle.



4. With the engine cool, remove the cap on the engine coolant degas reservoir bottle and the upper radiator fill cap. Drain the coolant using the petcock located on the lower passenger side of the radiator. Tighten the petcock once the engine coolant has been drained.

**TIP:** Connect a 3/8" hose to the drain fitting next to the petcock and run into a clean drain pan or bottle. Use a flat-blade screwdriver to open petcock and allow coolant to drain out of the fitting.



## 2018 Ford F-150 5.0L ROUSHcharger Kit SECTION A - DISASSEMBLY



5. Disconnect the PCV fresh air inlet tube from the left-hand (driver side) cam cover and the clean air tube. Remove hose from vehicle. Disconnect the brake booster vacuum hose from the clean air tube. Disconnect the clean air tube from the throttle body and the upper air box lid. Remove the clean air tube from the vehicle. Neither of these components will be reused.



- Remove the retaining bolt on the RH side, lift up and remove the air box.

6. Disconnect the heater hose quick connect fitting on the front driver side of the engine. Position this hose aside.



7. Pull up the two (2) retainers.



8. Remove the PCV purge line from the intake manifold and passenger side cam cover. This line will not be reused.



9. Disconnect the white quick-connect fitting from the brake booster.



10. Disconnect the throttle body electrical connector. (Pull the red locking tab back; press the black release tab to disengage the lock.) Refer to figure shown.



11. Disconnect the VMV (evaporative emission canister purge valve) tube and electrical connector. Remove the VMV tube retainer from the fuel rail and fuel supply line.



12. Disconnect the fuel supply line on driver side from the fuel rail. Refer to figure shown below. Use rags to catch fuel.



13. Use a 3/8" disconnect tool to disconnect the high pressure fuel line (RH side).



14. Disconnect the brake booster vacuum hose from the intake manifold. This port is located directly behind the throttle body.

16. Remove the 3/8" engine coolant degas hose from the connection at the engine and place the loose end of the hose to the side for later connection.



15. Disconnect the brake booster vacuum line from above brake master cylinder (only for 4x4).

17. Disconnect degas upper bottle-to-radiator hose.



18. Remove two (2) mounting bolts.



19. Disconnect degas-to-engine lower hose from the port on the engine and remove degas bottle from vehicle.



20. Remove and discard the LH and RH fuel rail insulators.



21. Disconnect the eight (8) fuel injector electrical connectors.



22. Disconnect the fuel regulator electrical connector from the sensor on the LH fuel rail.



23. Remove the four (4) fuel rail bolts. Three (3) of the four (4) bolts will be reused. **NOTE:** It is not necessary to remove the fuel rail from the intake manifold assembly.



25. Remove the remaining six (6) intake manifold mounting bolts. Lift up and move the manifold forward enough to access and remove the retaining pins attaching the wiring harness at the back of the manifold. Remove the intake manifold and fuel rail assembly from the vehicle. This hardware will not be reused.



26. Carefully disconnect the four (4) harness connectors (circled) from the rear of the intake manifold. Remove the two (2) push pins attaching the wiring harness to the manifold; retain the push pins for reuse at installation.

24. If you wish, lift up and remove the fuel rail. It is not necessary.





28. Disconnect the upper radiator hose from the engine.

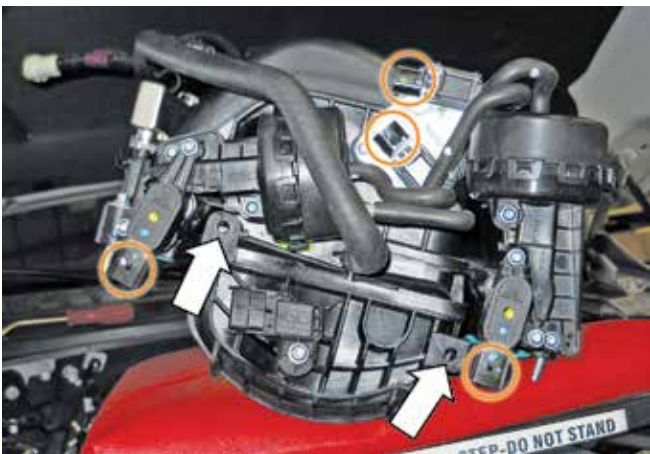

27. Clean the intake mounting surfaces and apply tape over the open intake ports to prevent engine contamination.



**2018 Ford F-150 5.0L ROUSHcharger Kit  
SECTION A - DISASSEMBLY**



29. Loosen the three (3) water pump pulley bolts, and then remove the front engine accessory drive (FEAD) belt. Rotate the FEAD tensioner counter-clockwise to release the belt tension and remove the belt.

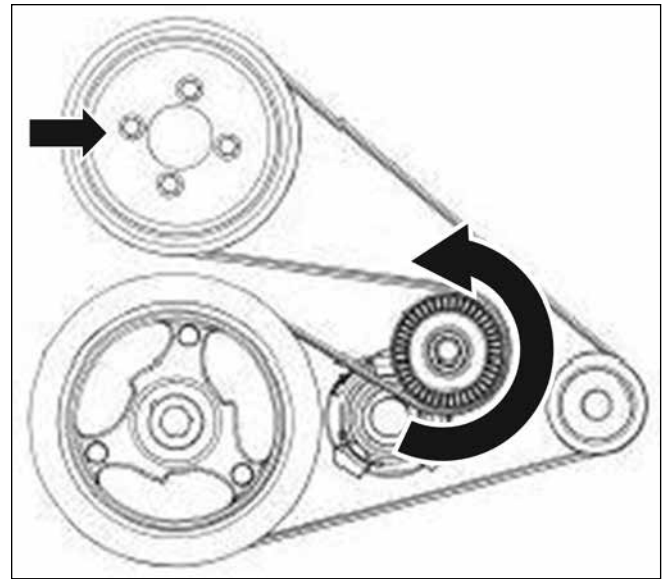

30. Remove the three (3) bolts securing the water pump pulley to the engine.

31. Release the tension and remove A/C compressor belt from the engine. Then remove the tensioner and the idler; these parts will not be re-used.





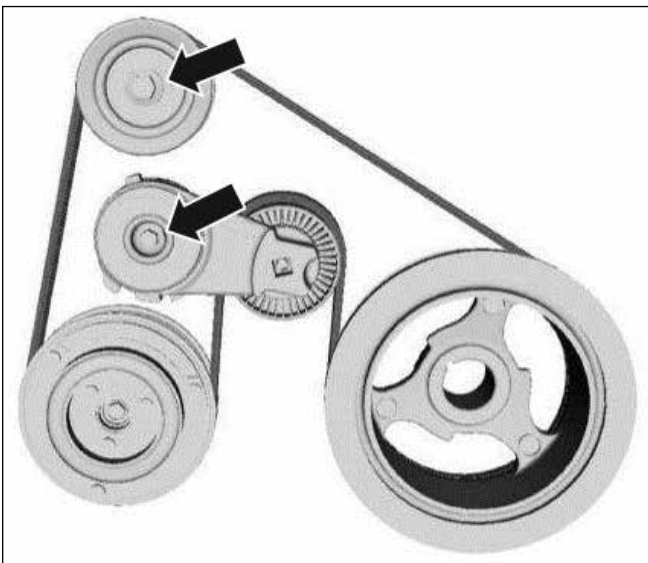

## SECTION B – MODIFICATIONS

The following section will guide you through the required modifications of existing components and build up of the assemblies used to complete the installation. With the exception of the wiring modifications and the A/C compressor clutch assembly R&R, all of this work can be performed away from the vehicle.

### A/C COMPRESSOR PULLEY REPLACEMENT

#### A/C Clutch Disc and Hub Bolt Removal

1. Using the A/C Clutch Holding Tool, hold the A/C clutch disc and hub.
2. Remove the A/C clutch disc and hub bolt.

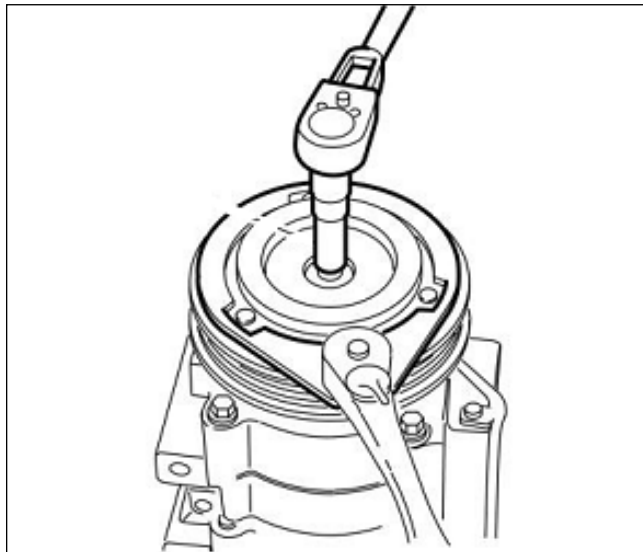

3. Remove the A/C clutch disc and hub.
4. Remove the A/C compressor pulley snap ring.

#### Compressor Pulley Removal

**NOTICE:** Do not use air tools. Damage to the air conditioning (A/C) clutch pulley or A/C compressor may result.

1. Install the Compressor Pulley Remover.
2. Remove the A/C compressor pulley.

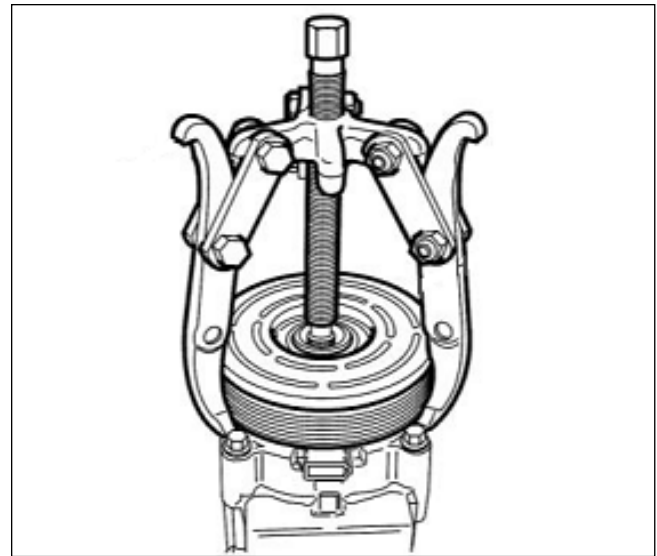

#### Compressor Pulley Installation

1. Clean the A/C pulley mounting surfaces.

**NOTE:** The A/C compressor pulley is a tight fit on the A/C compressor. It must be correctly aligned during installation.

2. Install the A/C compressor pulley (1120-68319162).
3. Install the A/C compressor pulley snap ring with the bevel side out.
4. Place one nominal thickness A/C clutch disc and hub spacer inside the clutch hub spline opening.

#### A/C Clutch Disc and Hub Bolt Installation

1. Using the A/C Clutch Holding Tool, hold the A/C clutch disc and hub.
2. Tighten the bolt to 14 Nm.

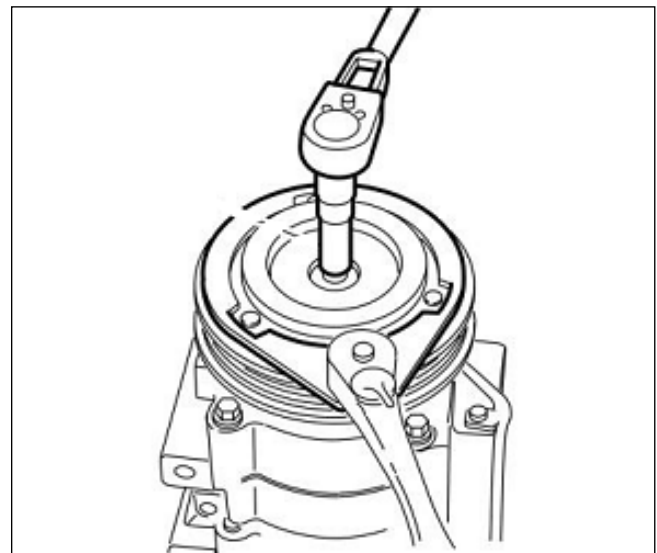

3. Measure and adjust the clutch air gap at three (3) spaces by removing or adding A/C clutch disc and hub spacers.

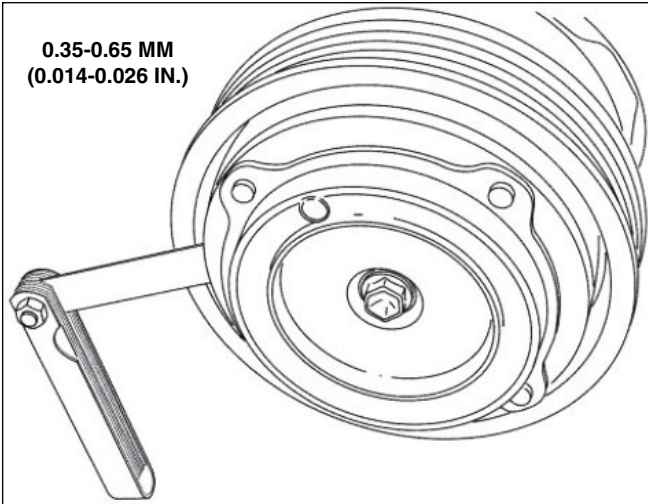

### Pulley Installation

**NOTE:** If not secured within 5 minutes, the sealant must be removed and the sealing area cleaned with silicone gasket remover and metal surface prep. Failure to follow this procedure can cause future oil leakage.

### CRANKSHAFT PULLEY REPLACEMENT

**NOTE:** After crankshaft pulley installation, it will be necessary to relearn the misfire profile correction using RDT. Refer to the RDT-CALIM included with your ROUSHcharger kit.

#### Pulley Removal

1. Loosen the crankshaft pulley bolt and washer.

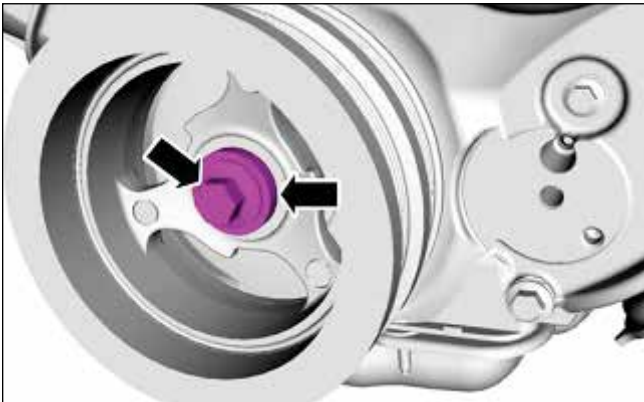

2. Using a 3-Jaw Puller and the crankshaft pulley bolt, remove the crankshaft pulley. Discard the crankshaft pulley bolt.



2. Lubricate the crankshaft pulley sealing surface with clean engine oil prior to installation.



3. Using a suitable Damper Installation Tool, install the crankshaft pulley.

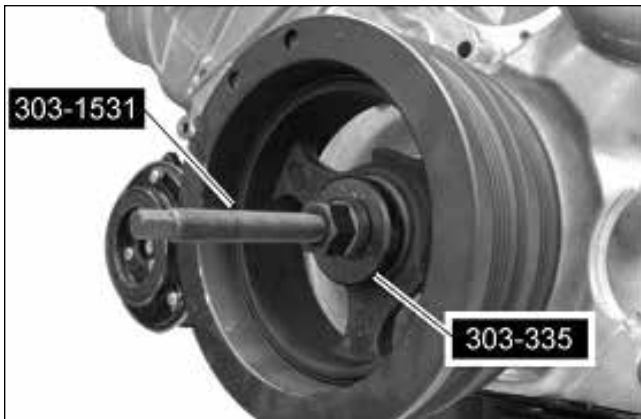

4. Using the Strap Wrench, install a new crankshaft pulley bolt (BR3Z-6A340-A) and the original washer. Tighten the bolt in four (4) stages:
  - Stage 1: Tighten to 140 Nm.
  - Stage 2: Loosen 360 degrees.
  - Stage 3: Tighten to 100 Nm.
  - Stage 4: Tighten an additional 90 degrees

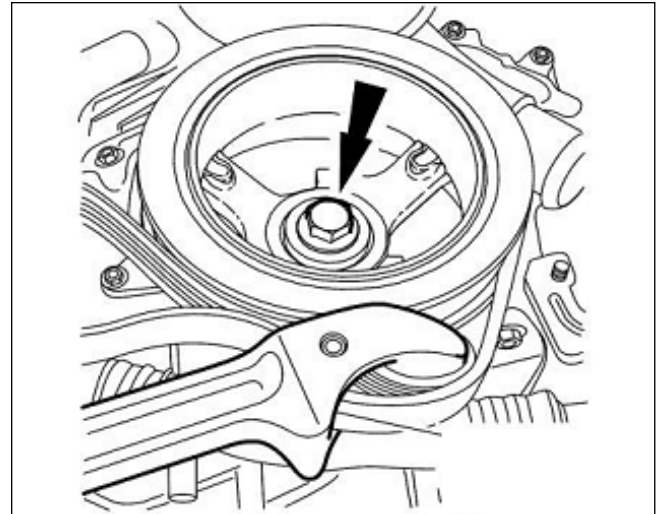

### TRANSMISSION COOLER LINE BRACKET BOLT REMOVAL

In order to access a bolt required to install the FEAD tension bracket, the transmission cooler line bracket must be removed from its current position.

1. Use a suitable type of side cutters to remove the tabs on the bracket.



2. Bend the flat part of the bracket apart.



3. Remove the bolt from the bracket.



6. Use a pry tool to pry out the wiring harness bracket.



4. Separate and remove the bracket from the stud. Discard the bracket.



7. Remove the bolt. The line and wiring harness will need to be fastened to the tensioner bracket in a later step.



5. Use a cut-off wheel to cut the stuff off at the base.





### BRAKE BOOSTER HOSE AND ASPIRATOR ASSEMBLY MODIFICATION

**NOTE:** Steps 1-4 are for Job1 2018 F-150. Steps 5-7 are for Job2 2018 F-150. Job2 F-150s can order Ford part JL3Z 2420 E for a cleaner installation.

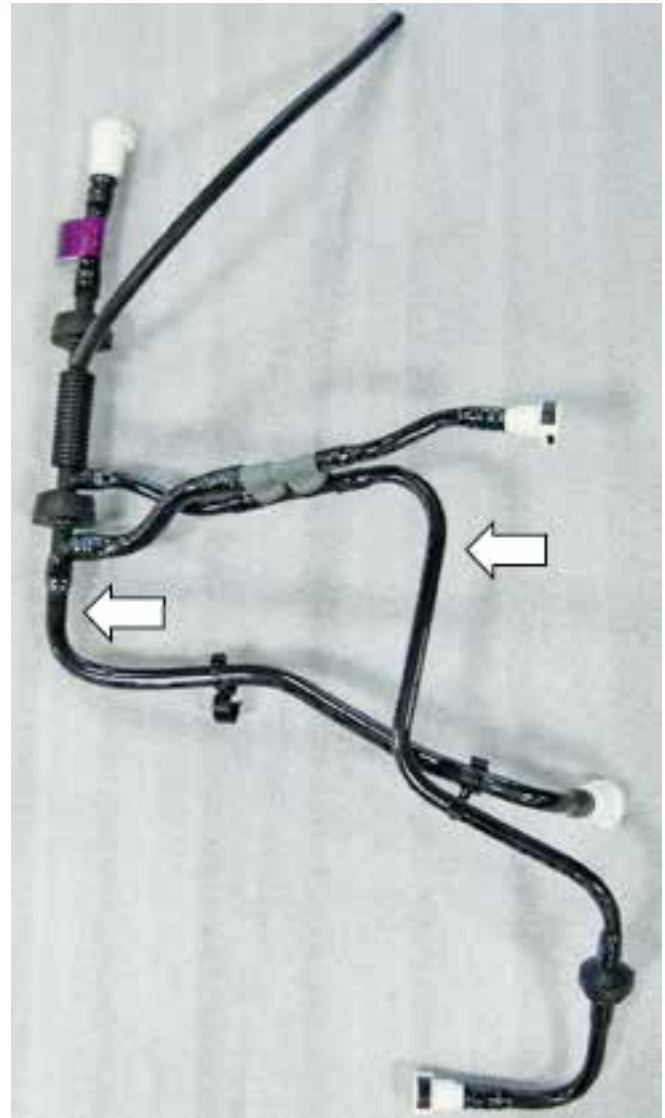

F-150 Job1



F-150 Job2

1. With the brake booster hose and aspirator assembly removed from the intake manifold, locate the stock clean air tube hose with the quick-connect fitting.

2. Carefully cut and remove the two (2) hoses shown. The removed hose is not reused.



3. Install a cap (CS2575, found in 1118-TVSHWKD) in the port where the hose was removed.



4. Slide the clamp away from the check valve and the factory aspirator-to-throttle body hose. Replace the removed hose (top) with the new formed EPDM aspirator-to-throttle body spacer hose (1115-9D692, found in 1118-KIT4) (bottom), and install it on the brake aspirator assembly. Use clamp (62003, found in 1118-TVSHWKD) to secure the hose to the assembly.



5. Carefully cut and remove the two (2) hoses shown. The removed hose is not reused.



6. Install a cap (CS2575, found in 1118-TVSHWKD) on the smaller port.



7. Install the brake aspirator hose (1115-9D691, found in 1118-TVSHWKD) as shown. Use the clamp (62003, found in 1118-TVSHWKD) to secure the hose to the assembly.



#### A/C LINE MODIFICATION

Position the A/C line as shown and pull forward to bend the line slightly to reposition it for more clearance at the front of the engine.

**NOTE:** You should be able to pass a 1/4" drive extension through this area when the tensioner bracket is installed.





**FRONT COVER MODIFICATION**

**⚠ WARNING**

**Wear safe eye protection when grinding to prevent serious personal injury.**

1. Remove the bolts from the auxiliary water/heater pump.



2. Move it aside to access the cover for modification.



3. Disconnect the electrical connector.



4. Pry the pump free from the retainer.



5. Move the auxiliary water/heater pump out of the way to access the front cover for modification.



6. If not already done so, clean the engine surfaces with brake clean and dry with shop air.
7. Mask off the surrounding areas where the grinding will be performed to prevent debris and metal shavings from spreading through the engine compartment.



8. Locate the boss circled in red on the front cover. This boss needs to be reduced in height such that it is flush or lower than the height of the nearby rib structure. Apply reference marks on the boss to guide this modification.

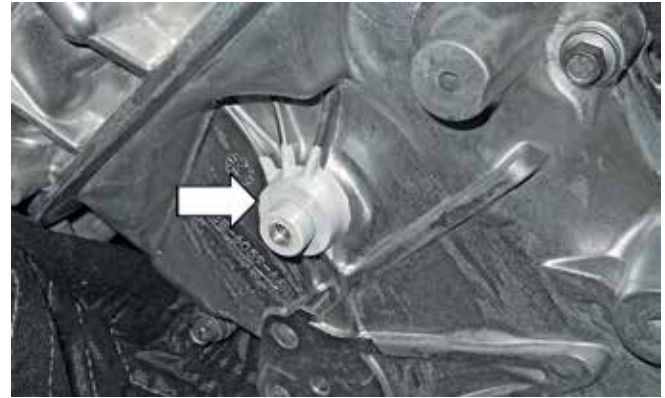

**Before**

9. Using a grinder or cut-off wheel, modify the front cover in the area shown. Check that the area where the boss was is now flush or lower than the height of the nearby rib structure.

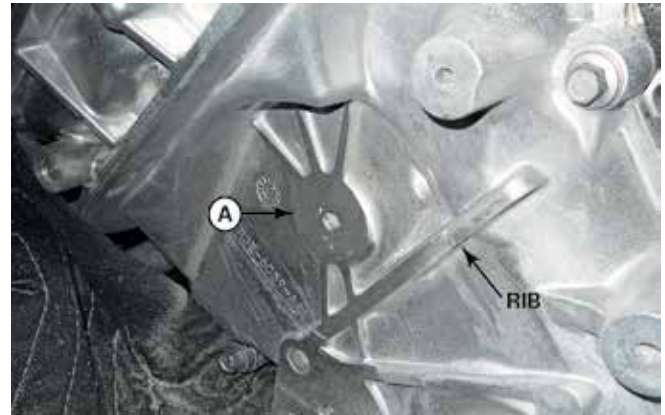

**After**

Surface A must be lower than or equal to the adjacent rib height. Refer to the following close-up example views for detail.

10. Locate the boss circled in green on the front cover. Drill the hole to a depth of 35 mm from the surface using a 6.9 mm drill bit. (The depth is important since it will be tapped to a depth of 25 mm minimum.)

**NOTE:** Drilling too deep could cause potential oil leaks.



11. Tap the hole using a M8x1.25 tap. Verify that the threads are at least 25 mm past the surface.



12. Vacuum out the metal shavings and clean the area.

### INTERCOOLER PUMP HARNESS PROCEDURE

1. Obtain the intercooler pump electrical harness (1320-8W501-AB). Route and tuck the pump harness under the engine harness along the RH cam cover. Continue routing the harness to the rear of the cylinder head and over to the driver side inboard cylinder head.



2. Install the M8 J-clip (W520823-S439) over the hole in the front corner of the battery box as shown.



3. Install the relay and fuse from the intercooler pump wiring harness (1320-8W501-AB) onto the J-clip. Use one (1) M6 x 1.0 x 20 bolt (W500214-S437) to secure the relay and fuse to the J-clip. Torque the bolt to 5 Nm.



## 2018+ Ford F-150 5.0L ROUSHcharger Kit SECTION B - MODIFICATIONS

4. Route the black ground wire from the I/C pump harness along the chassis and up the radiator support to the passenger side of the vehicle to the factory ground on the body, torque to 10 Nm.



5. Route the red wire (part of the intercooler pump wiring harness installed above) to the positive terminal of the battery cable. Remove the nut from the positive terminal and install the red wire eyelet. Reinstall the nut onto the terminal and torque to 10 Nm.



6. Remove factory push pins and zip ties from factory wiring to allow wires to be moved into position for connection.



7. Disconnect the transmission connector and take off backing. The connectors are labeled.



8. With a small Allen wrench, remove knock pins in locations 12, 28 and 80.

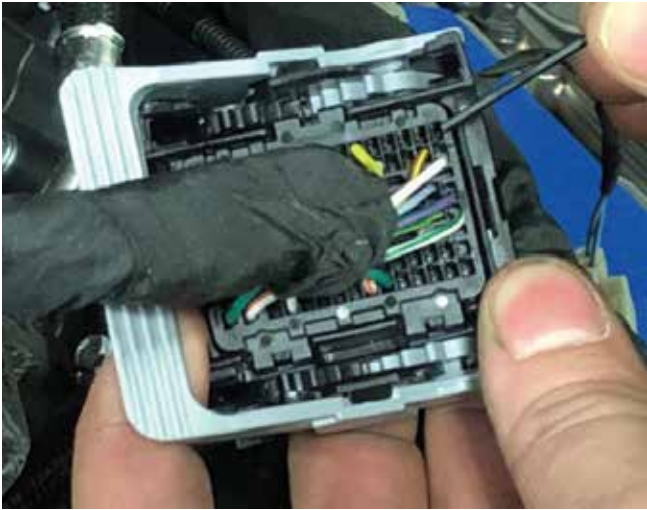

9. From the MAF to MAP harness (1318-12B579W-AB) [put the wires into the transmission connector in location 12 (black), 28 (red) and 80 (green)]. The wires are fully seated when you hear a click.



11. Route the MAF to MAP harness around the back. Make the connections. Pay attention to the wire colors. The harness should match perfectly to the factory colors; a yellow with a red tracer, a yellow with a green tracer and a purple wire.



10. Put backing back on, zip tie the wires at the back and re-connect the transmission connector.



12. The other connection will also have matching colored wires to the factory connection. Make sure that they are aligned when connecting. Grey, blue with a white tracer and a yellow with a green tracer.



13. Zip tie the harnesses so they are out of the way. Cut the tails of the zip ties.



2. Plug in the two (2) small connectors from the harness behind the LH and RH cylinder heads.  
**NOTE:** The wire color will match the correct IMRC connector. Verify the colors match during installation.

### MAF-TO-MAP HARNESS

1. Route the MAF-to-MAP harness (1318-12B579W, found in 1120-TVSHWKE) behind the cylinder head.





3. Zip tie the harness to the engine harness all around the cylinder head.



LH cylinder head



RH cylinder head

**MAF WIRES TO PCM LINE**

1. Disconnect the top PCM connector from the PCM. The connector is located near the wiper fluid bottle at the front of the vehicle.



2. Depress the two (2) tabs and remove the cover off the back of the connector.



3. Remove the lock window from the connector by pushing it out from the backside. Pull the lock window off the front.



4. Punch out the blank in Pin 12. Insert the black wire from the MAF-to-MAP jumper connector and push in until you feel it lock in place.



5. Punch out the blank in Pin 28 and insert the red wire.
6. Punch out the blank in Pin 80 and insert the green wire.
7. Reinstall the lock on the front of the connector.
8. Reinstall the cover on the back of the connector.



9. Plug the PCM connector back in.
10. Plug the jumper connector into the MAF-to-MAP Harness.



### KNOCK SENSOR ORIENTATION ADJUSTMENT

The knock sensors must be reoriented and the harnesses rewrapped to accommodate the new fuel charging assembly. It will be necessary to split the four (4) sensor wires further up the harness in order to gain the necessary slack for proper sensor positioning.

1. Remove the isolators from the valley. They will not be reused.



2. Remove the two (2) push clips in the valley and cut them off the harness.





3. Cut the knock sensor harness back.



4. Remove the four (4) bolts which retain the knock sensors to the engine block (13 mm socket). Discard the bolts.



5. Temporarily fit the sensors as follows to determine where to rewrap the wires. Install and rotate the RH and LH knock sensors as far as possible to

the outside of the valley of the block. Check that the sensors lay low on the engine valley so they will not interfere with the fuel charging assembly once it is installed.



6. Reinstall the convolute and rewrap the wires with electrical tape as required.
7. Install the knock sensors in position. (Point the connectors towards the center.) Apply Loctite 242 to the threads of the new bolts. Install the new bolts (92095A292, found in 1118-TVSHWKB) and torque them to 20-30 Nm (5 mm Hex socket).

#### **CHANGING THE FACTORY SPARK PLUGS**

1. Disconnect the electrical connectors for each ignition coil (seven [7] places) (except cylinder 3).



2. Remove the fasteners holding the coil on plug assemblies in place (8 mm socket). Save the fasteners for re-use.



4. Use a 5/8" spark plug socket and 6" extension to remove the eight (8) factory spark plugs and set them aside. The spark plugs will not be re-used.

**NOTE:** Use a universal swivel socket at the rear RH plug.



3. Remove the coil on plug assemblies and label them so they can be reinstalled in their original positions. A slight twisting motion will break the seal and ease removal.



5. Unpack the eight (8) provided spark plugs (M-12405-M50A, found in 1318-KIT2) which are pre-gapped to 0.028-0.031" (0.7-0.8 mm). Use a 0.031" feeler gauge to ensure the gap is intact and none are damaged.



6. Apply Loctite silver grade anti-seize to the plug threads.



7. Install the new spark plugs using a 5/8" spark plug socket and 6" extension. Torque to 14 Nm.
8. Apply a small amount of dielectric grease to the inside of the coil on plug boots before attaching to the spark plugs. Install the ignition coil on plugs in their original position. Install the coil on plug bolts and torque to 6 Nm.
9. Connect the electrical connectors for each ignition coil in seven (7) places.

**SECTION C – SUBASSEMBLY**

**AIR BOX ASSEMBLY**

1. With the stock dirty air duct and air box tray assembly removed from the vehicle, remove the bolt securing the duct in place on the air box tray. Separate the tube from the air box; the air box tray will not be reused. Keep the bolt for reuse.



3. Transfer and assemble the stock dirty air duct to the new airbox tray (1115-9A612). Install the factory bolt to secure the duct in place. Torque the bolt to 3 Nm.

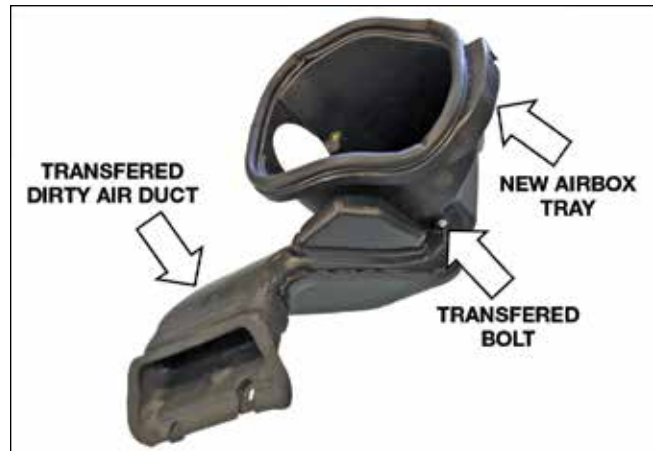

2. Remove the grommet and sleeve from the factory air box and install them on the new air box.

4. Install the air filter (131550-9601R) on the MAF tube (111550-12B579) and secure it with the supplied clamp. Torque the clamp to 3 Nm.

## 2018 Ford F-150 5.0L ROUSHcharger Kit SECTION C - SUBASSEMBLY

5. Insert the MAF tube and filter into the airbox tray and secure in place with two (2) M8 x 1.25 x 25 bolts (W500224-S437, found in 1118-TVSHWKA). Torque the bolts to 10 Nm.



2. Install the 3/8" SAE fitting (KLR-9N285) and 5/8" SAE fitting (1311-9N285) found in 1118-TVSHWKA in the respective ports on the clean air tube.

6. Install the airbox cover (1118-9643HC) onto the box. Use the self-tapping screws (W506976-S437, found in 1118-TVSHWKA) to fasten the lid to the box. Do not overtighten.



**\*Note\*** IF THE ROUSH AIRBOX LID DOES NOT HAVE A HYDROCARBON TRAP ON THE UNDERSIDE OF THE LID, REFER TO APPENDIX A AT THE END OF THIS DOCUMENT ON PAGE 65.

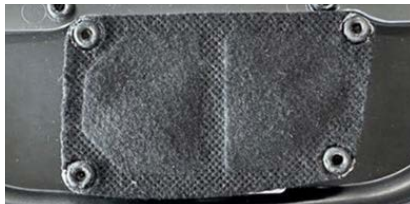

### CLEAN AIR TUBE ASSEMBLY

1. Install new grommets (1150-58GRMT, found in 1118-TVSHWKA) on the bottom of the clean air tube assembly (1118SC-9B660).



3. Using two (2) hose clamps (R07130015-13, found in 1118-TVSHWKA) and (2) hose clamps (1368016100, found in 1118-TVSHWKA), install the cuff, T-body-to-CAT (1118SC-9B662) and the coupler, MAF-to-CAT (1115SC-9B661) on the respective ends of the clean air tube (1115SC-9B660) as shown.



**INTERCOOLER LOW TEMPERATURE RADIATOR (LTR)**

1. Position the low temp radiator (LTR) (1115-8K229) on your work surface with the inlet and outlet ports facing down as shown.



2. Apply foam tape cut from the bulk tape (1115-8K229FOAM, found in 1118-TVSHWKH) to the top and two (2) sides of the LTR.

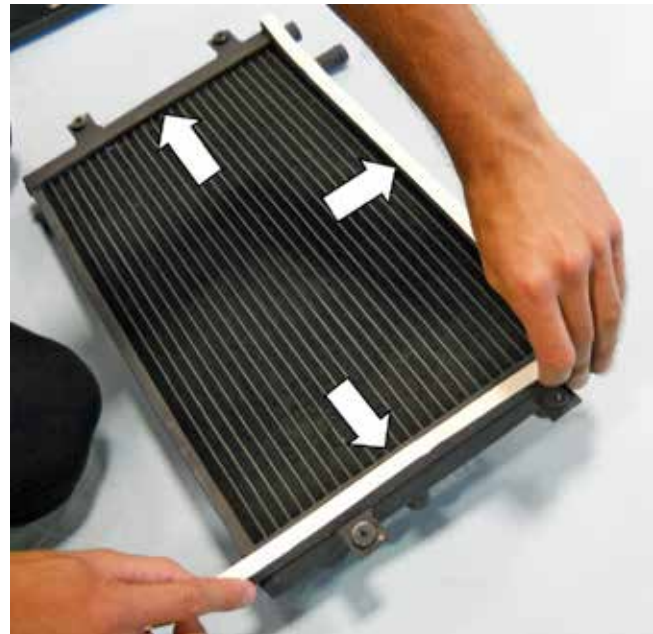

3. Remove the protective backing from the foam tape. Place the LTR air deflector (1115-5K235) in position over the LTR using care to align the mounting holes. Install the four (4) M6 x 20 bolts (W500214-S437, found in 1118-TVSHWKG) to attach the deflector (1115-5K235) to the LTR. Torque the bolts to 10 Nm.



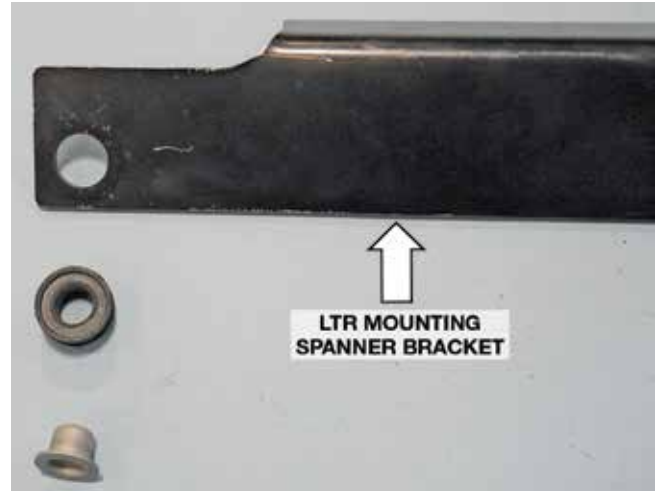

4. Insert a grommet (R07060107-13) and a steel grommet insert (R0706108-13) found in 1118-TVSHWKG into the vehicle frame mounting holes of the two (2) LTR mounting brackets, lower LH (1118-8K243) and lower RH (1118-8K242) found in 1118-TVSHWKH and the LTR mounting spanner bracket (1115-8K241).

5. Position the two (2) LTR lower mounting brackets into place on the LTR. Loosely install one (1) M8 x 1.25 x 20 bolt (90386A108, found in 1118-TVSHWKHD) through the non-grommet/insert bracket hole of each bracket and secure to the threaded boss on the LTR (two [2] places).

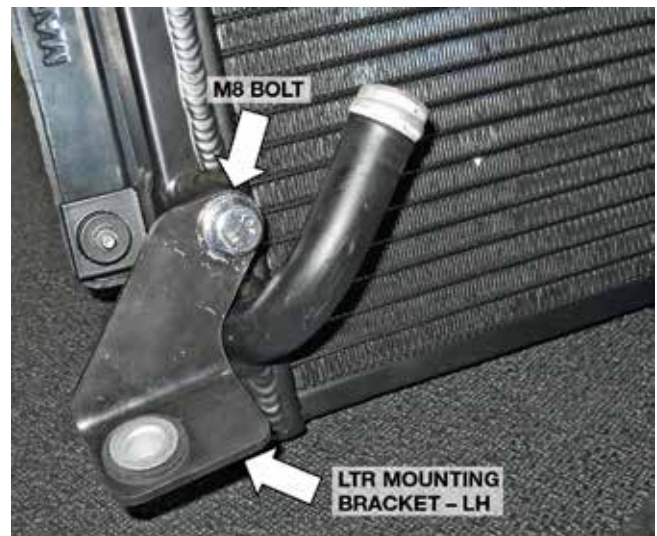
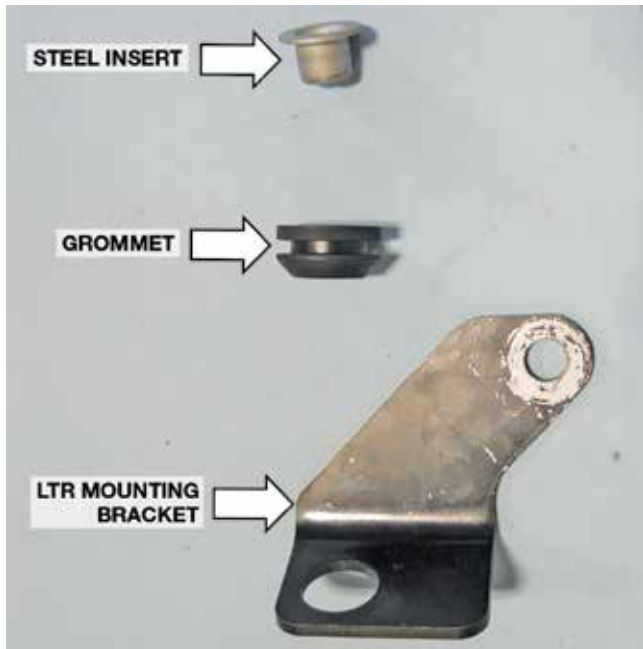





- The LTR spanner bracket (1115-8K241) attaches to the two (2) threaded bosses located at the upper end the LTR. Do NOT attach the bracket at this time. The spanner bracket must be installed on the vehicle before the LTR assembly is attached. This will be done later in SECTION D – INSTALLATION.

**NOTE:** The intercooler pump (1318-8501) will be installed on the LTR spanner bracket after the bracket and the LTR have been installed on the vehicle.



### INTAKE MANIFOLD BUILD UP

- Remove the fuel charging assembly (1318-9H487) from the packaging.
- Obtain the PCV purge hose (1318-6K817, found in 1118-KIT4). Release the clamp and separate the rubber section of the hose as shown.



- Attach the rubber hose from the PCV purge hose (1318-6K817) to the bubbler fitting (3/8" barb) on the bottom of the fuel charging assembly and secure it with the supplied clamp.



### SUPERCHARGER BUILD UP

- Connect the supercharger boost bypass actuator hose (1318-9E498, found in 1118-TVSHWKD) to the top port on the actuator and route to the small port on the supercharger (1318-6F066).



## 2018 Ford F-150 5.0L ROUSHcharger Kit SECTION C – SUBASSEMBLY

2. Install the SIP takeout sensor from the stock F-150 intake manifold into the side of the supercharger and secure it using one (1) bolt (N807309-S437, found in 1118-TVSHWKB). Torque to 10 Nm (10 mm socket).

**Important:** Do not confuse the sensor and fastener with identical parts.



3. Install the O-ring/gasket (1318-9E936, found in 1118-TVSHWKB) into the groove on the supercharger.



4. Install the throttle body (M-9926-M50BRSH found in 1318-KIT2) on the supercharger, making sure the part orientation is correct with the plug under the pulley. Install four (4) M6x1.0x45 mm bolts (161817, found in 1118-TVSHWKB) to secure the throttle body to the supercharger. Torque to 10 Nm (10 mm socket).



5. Install the supercharger badge (1318-6F066BDG, found in 1118-TVSHWKF) onto the top of the supercharger.



### FUEL RAIL ASSEMBLY

1. Carefully install the eight (8) take-off anti-rotation fuel injector clips onto the new fuel injectors (13119F593K, found in 1318-KIT2).



2. Apply a little engine oil or petroleum jelly to the Injector O-rings and install the injectors into the new fuel rail (1318-9F792, found in 1318-KIT2).



4. Install the pressure sensor in the new fuel rail. Hold the nut with a 19 mm wrench and use a 27 mm socket to tighten as follows.  
Stage 1: Torque the nut to 53 lb-in (6 Nm).  
Stage 2: Angle tighten the nut 25 degrees.



**NOTE:** Verify that the anti-rotation clips are properly aligned and fully engaged into the fuel rail injector cups.

3. Remove the pressure sensor from the stock fuel rail (27 mm socket).





### INTERCOOLER HARD LINE ASSEMBLY

1. Set the intercooler hard line assembly (1318-8D028, found in 1118-KIT4) on a work bench.



2. Install the 3/4" jumper hoses (1318-8D032, found in 1118-KIT4). Install one (1) heat shrink band (32929, found in 1118-TVSHWKG) over each hose.



3. Use a heat gun to heat the bands on high setting for 35 seconds evenly around each band until the hoses are secure on the tubes.

## SECTION D - INSTALLATION

The following section will guide you through the final installation of the kit into the vehicle. If you need to stop during any part of the installation, make sure you cover any open ports in the cylinder heads or intake manifold to prevent foreign material from contaminating your engine.

### INTAKE MANIFOLD AND FUEL RAILS

1. Remove the tape from the cylinder heads and clean the cylinder head-to-intake manifold mating surfaces.
2. Install the fuel charging assembly (1318-9H487) and check to make sure it is seated completely. Route the PCV hose under the DI fuel rail as the intake manifold is being slid into position.



3. Plug in the connector to the MAP sensor on the front of the intake manifold.



4. Loosely install the six (6) M6x1.0x40 mm bolts (R18020004, found in 1118-TVSHWKB) in the intake manifold in the positions shown. Do not tighten yet.

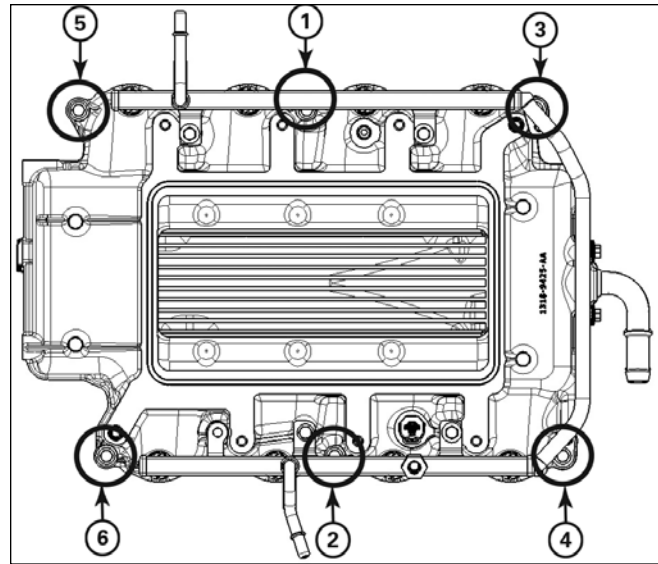

#### Intake manifold bolt tightening sequence

5. Install two (2) clamps (CT19X12, found in 1118-TVSHWKG) on the tubes at the rear of the intake manifold. These clamps will secure the hoses from the intercooler hard line assembly when installed.



6. Temporarily place the intercooler hard line assembly (1318-8D028) in position on the LH valve cover and connect the hoses to the tubes on the rear of the intake manifold. Test the fit to ensure the hoses are not kinked.

# 2018 Ford F-150 5.0L ROUSHcharger Kit SECTION D - INSTALLATION



**NOTE:** Check that the PCV hose in back of the intake manifold is routed around the DI injector crossover tube and towards the RH cam cover.

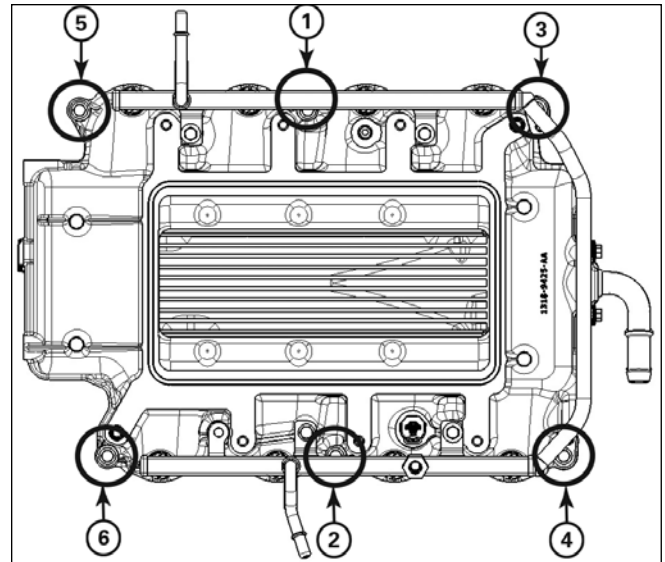

7. Tighten the intake manifold bolts to the following specification.  
Stage 1: Torque the bolts to 10 Nm.  
Stage 2: Tighten the bolts an additional 45 degrees. Reinstall the engine wiring harness retention clips at the rear of the intake manifold.



8. Remove the bolt (8 mm socket) from the coil cover.

Place the intercooler hard line assembly in mounting position and reinstall the bolt. Torque to 6 Nm.



9. Secure the CAC hoses at the rear of the intake manifold with the two (2) clamps (CT19X12).



10. Connect the ACT sensor to the ACT harness (1318-12B579W).



11. Lubricate the lower fuel injector O-rings with petroleum jelly or engine oil. Install the fuel rail and injectors into the intake manifold. **leave passenger side loosely installed.** Be sure each injector is properly seated into the intake manifold. Be sure each injector is properly seated into the intake manifold. Install the one (1) previously removed fuel rail mounting bolts into fuel rail mounting location five (5) in the figure to the right.



12. Install the M6x1.0x20 fuel rail-to-intake manifold bolt (BM6X20HF-S437) (short) at **position 2** and M6x1.0x45 fuel rail to cylinder head bolt (161817)(long) at **position 4**. Bolts are found in 1121-HWKB. Tighten the bolts in two stages in the sequence shown. Install original takeout bolt in **position 5**.

Stage 1: Torque the bolts to 10 Nm.

Stage 2: Tighten bolts 5 an additional 45 degrees. Do not angle tighten bolts 2 and 4.

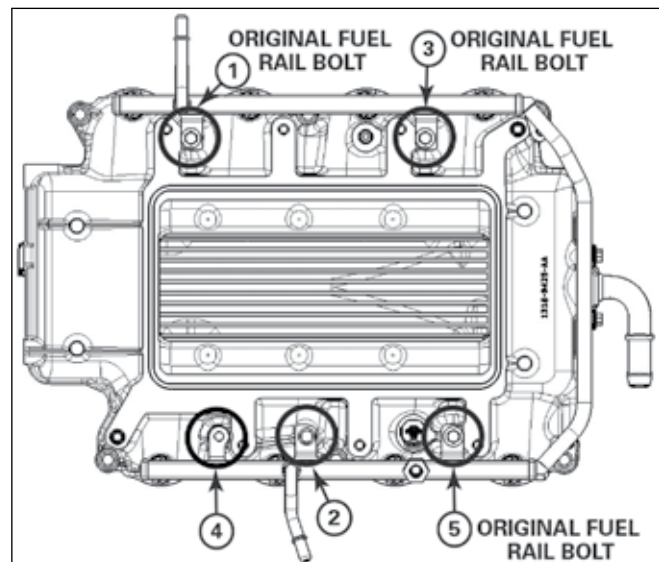

Fuel rail bolt Diagram

**NOTE: Passenger Side Fuel Rail will be tightened AFTER supercharger assembly is installed**



13. Connect the eight (8) fuel injector electrical connectors.



14. Plug in the connector to the fuel pressure sensor on the fuel rail.



### UPPER FEAD BRACKET

1. Place the upper FEAD bracket (1318-8B653U, found in 1318-KIT3) in position on the FEAD.



2. Install four (4) upper FEAD bracket-to-engine bolts (M8x1.25x60) (11116346). Install one (1) silver upper FEAD-to-intake (M8x50) bolt (W500313-S437), in the upper left corner. Torque to 25 Nm. All the bolts in this step are found in 1318-TVSHWKC.



3. Install the black 77 mm grooved idler pulley (900162, found in 1118-TVSHWKC) on the upper right of the FEAD bracket with one (1) idler bolt (M8x1.25x28\_large washer) (R18020060). Torque to 25 Nm. Install the silver 70 mm smooth idler pulley (34-0284, found in 1118-TVSHWKC) on the lower left of the FEAD bracket with one (1) idler bolt (M8x1.25x28\_large washer) (R18020060). Torque to 25 Nm.





### SUPERCHARGER

**NOTE:** Make sure the O-ring on the upper intake manifold is in position and has not rolled out of the groove.

1. Partially set the supercharger in place over the intake manifold over the throttle body wire.



2. Connect the stock throttle body harness to the jumper harness (1318-9F992). Connect the jumper harness to the throttle body connector and move the wiring out of the way.



3. Carefully install and seat the supercharger assembly (1318-6F066) in place on the intake manifold. Ensure that the supercharger is fully seated on the intake mounting dowels.



- 4a. Install the provided eight (8) M8 fasteners (161826, found in 1318-TVSHWKB) into the mounting holes. Torque the fasteners to 25 Nm in the sequence shown (13 mm socket).



4b. Install the Passenger side fuel rail fully from previous step and install takeout fuel rail bolts in **positions 1 and 3**. Torque in the following procedure:  
Stage 1: Torque the bolts to 10 Nm. Stage 2: Tighten bolts 1, 3 an additional 45 degrees

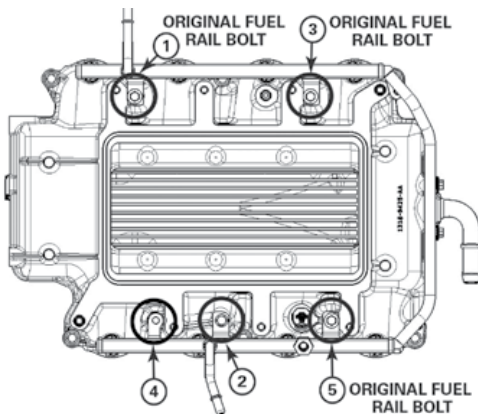

Fuel rail bolt diagram

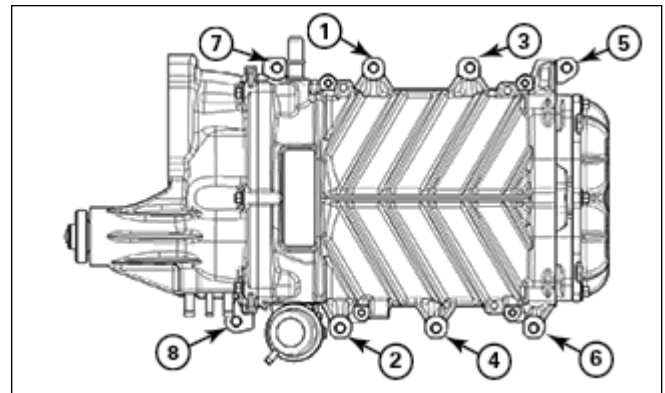

Supercharger bolt tightening sequence

5. Connect the SIP connector on the supercharger.



6. Place the brake booster hose assembly next to the supercharger, over the LH coil area.



7. Connect the check valve on the brake vacuum and aspirator assembly to the brake booster.



8. Install the brake booster hose assembly in the vehicle and inspect the fit to ensure there are not pinched hoses and the convolute is positioned to prevent hose abrasion from other components.

**NOTE:** Job1 PCV routing shown.



9. Connect the booster hose (1115-9D692) to the supercharger and secure it with one (1) clamp (7329K11, found in 1318-TVSHWKD).

**NOTE:** If building a Job2 2018 F-150, you will be connecting the 1115-9D6912 to the supercharger port shown.

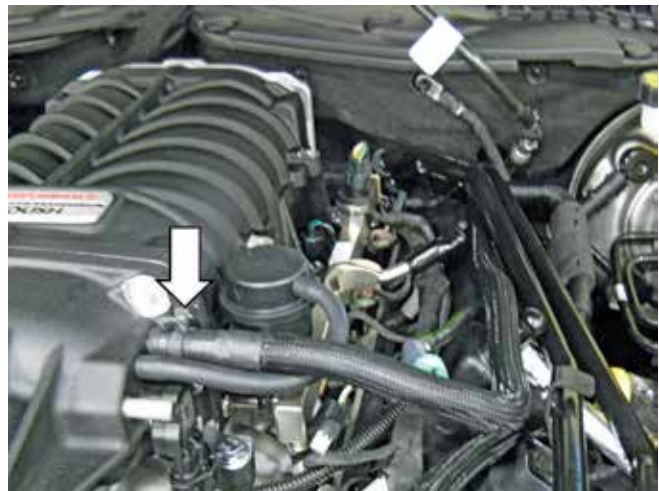



10. Install the hose (27004, found in 1118-TVSHWKD) between the supercharger and EECPV. Secure it with two (2) clamps (7329K11, found in 1318-TVSHWKD).



11. Install the connector to the EECPV. Install the purge line (with green connector) to the EECPV. Zip tie the EECPV to the engine harness.

**NOTE:** If using the Job2 PCV hoses, use foam M19-013-0066, found in 1118-TVSHWKD) on the bottom of the plastic diaphragm to keep it off of the supercharger.

12. Install the fuel inlet line to the tube on the LH fuel rail. Lock the connector.



13. Connect the high pressure fuel supply line to the RH fuel rail and lock it into position.



### PCV PURGE HOSE

1. Connect the fitting side of the PCV purge hose (1318-6K817) to the end of the hose that is already installed on the back of the intake manifold.

**NOTE:** Make sure both sides of the hose connections are locked onto the fitting. Pull on the hose to make sure the connections are secured.

2. Connect the PCV purge line (1318-6K817) to the PCV valve on the RH cam cover and the port on the RH side of the supercharger.



2. Route the FEAD belt (K060806, found in 1318-KIT3) as shown. Do not route the belt onto the supercharger pulley yet.



3. Assemble the idler pulley (34-0284) on the FEAD tensioner bracket assembly (1318-8B653) with one (1) bolt (11116112) and one (1) post (1318-8B653P).



**LOWER FEAD ASSEMBLY**

1. Remove the two (2) bolts from the front cover as shown.

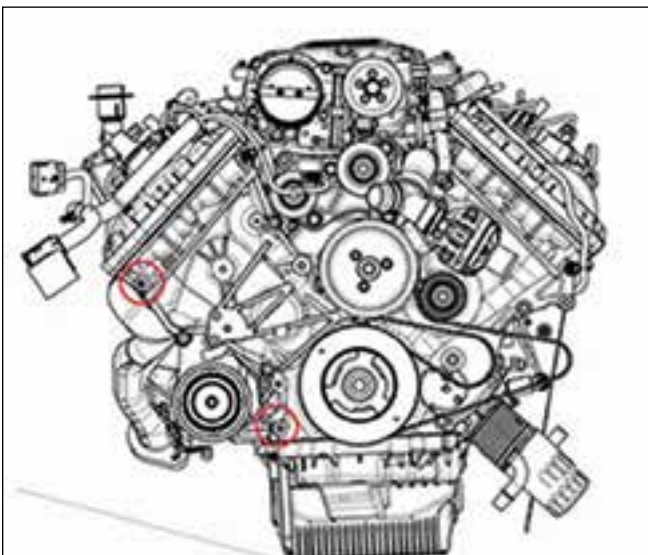

4. Loosely install the FEAD tensioner bracket assembly (1318-8B653) onto the front cover using two (2) M8x1.25x120 mm bolts (N811329) and one (1) M8x1.25x70 bolt (11116112, found in 1318-TVSHWKC) (10 and 13 mm sockets).

**NOTE:** Install the lowest bolt into the casting prior to positioning in vehicle, in order to clear the sway bar.



5. Feed the belt around the pulleys. Note the top RH bolt goes through the pulley. Torque the tensioner bracket bolts to 25 Nm.

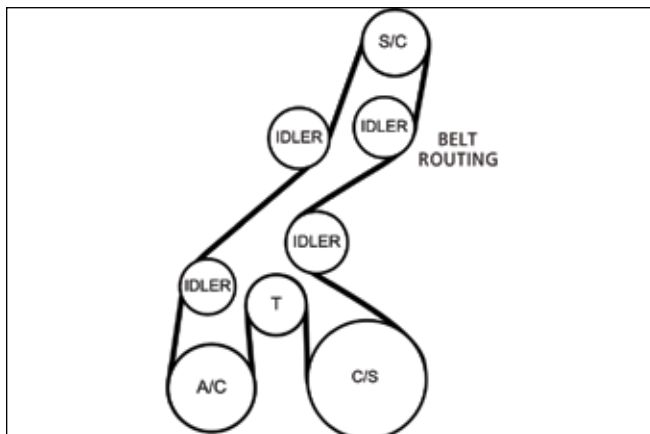

6. Using a 17 mm socket, rotate the new tensioner clockwise to install the belt on to the supercharger pulley. Inspect each pulley to ensure the belt is properly seated.



7. Re-install the water pump pulley using the three (3) removed bolts. Torque the bolts to 25 Nm (10 mm socket).



8. Re-install the stock FEAD belt (15 mm socket) by rotating the tensioner counter-clockwise and routing the belt as per the stock Ford belt routing.
9. Check the clearance between the FEAD "V" bracket and AC line. Make sure it has approximately 7 mm of clearance to avoid contact with the hose.
10. Install the heater hose on the LH cover.



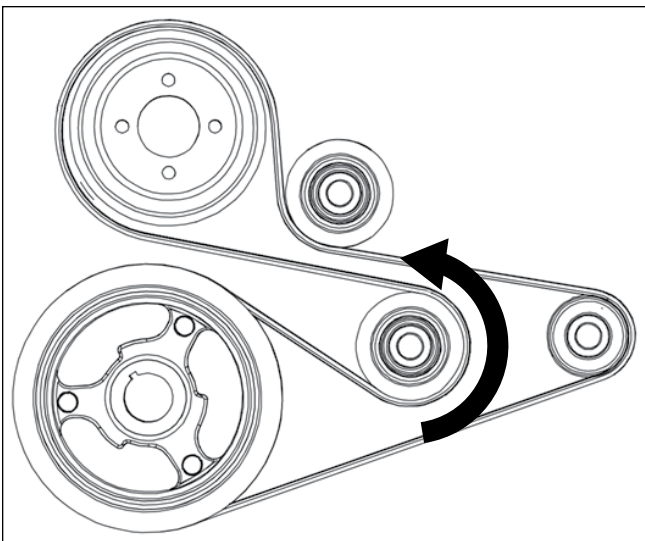

### INTERCOOLER RESERVOIR MOUNTING

1. Remove the bolt attaching the radiator overflow tank to the fan shroud at the left (driver) side. Set the bolt aside; this bolt location will be used for the degas bottle mounting bracket attachment.



2. Using the degas bottle-to-fan shroud mounting bracket (1115-6B634, found in 1118-TVSHWKH) as a template, mark and drill a new mounting hole in the fan shroud using a 1/4" drill bit.



3. Install a M6 J-clip (N623332-S439, found in 1118-TVSHWKD) over the drilled hole.



## 2018 Ford F-150 5.0L ROUSHcharger Kit SECTION D - INSTALLATION

4. Place the mounting bracket (1115-6B634) in position on the fan shroud with the RH mounting hole under the overflow tank and the left hole over the new J-clip. Install the original overflow tank bolt in the RH mounting hole and an M6 x 1.0 x 20 bolt (W500214-S437, found in 1118-TVSHWKD) to secure the bracket in the lower LH J-clip. Torque to 10 Nm.



5. Connect the bottom hose to the port and secure with clamp.



6. Install the degas bottle (1115-8D028, found in 1118-KIT4) over the two (2) studs on the mounting bracket. Install two (2) M6 nuts (W520412-S437, found in 1118-TVSHWKG), over the studs and torque to 10 Nm.



7. Connect the hose to the port and secure with clamp.



8. Connect the the hose to the bottle and secure with clamp.





## INTERCOOLER RADIATOR ASSEMBLY MOUNTING

1. Install the LTR mounting spanner bracket (1115-8K241) on the vehicle between the LH and RH frame rails as follows:
  - Locate the open hole in the top of the LH frame near the front and the corresponding open hole in the RH frame rail.
  - Insert an M8 x 1.25 J-clip (W520823-S439, found in 1118-TVSHWKG) through the opening in each frame rail and over the mounting hole.
  - Place the spanner bracket in position on top of the frame rails with the flange to the rear and facing down.
  - With the mounting holes aligned, install two (2) M8 x 1.25 x 29 bolts (N808920, found in 1118-TVSHWKG) to attach the spanner bracket to the frame rails. Torque to 25 Nm.



2. Remove the two (2) OEM bolts at the base of the bumper beam inboard of the LH and RH frame rails. These holes will be the attachment point for the lower LTR mounting brackets. The OEM bolts are not reused.



3. Place the LTR assembly (1115-8K229) in position between the spanner bracket at the top and the bumper beam.
4. Install two (2) M8 x 1.25 x 20 bolts (90386A108, found in 1118-TVSHWKG) to attach the LTR to the spanner bar. Torque the bolts to 25 Nm.



5. Align the lower LTR brackets with the open holes in the support panel and install the longer M8 x 1.25 x 33 bolts (N808920-S437, found in 1118-TVSHWKG) to attach the LTR brackets to the bumper beam. Torque the bolts to 25 Nm.



### INTERCOOLER PUMP MOUNTING

1. Place the intercooler pump bracket (1118-8C4192, found in 1118-TVSHWKH) (hoop-style bracket in photo) onto the intercooler pump (1318-8501, found in 1118-KIT4). Install the pump and bracket onto the intercooler pump mounting bracket (1118-8C4191, found in 1118-TVSHWKH) (larger bracket in photo) as shown and hand tighten the clamp bolt (W500214, found in 1118-TVSHWKG). Do not fully tighten the bolt at this time to allow for proper alignment of the inlet and outlet ports during installation in the vehicle.



2. Install the pump and bracket assembly on the LTR spanner bracket using two (2) M8 x 1.25 x 29 bolts (W500224-S437, found in 1118-TVSHWKG). Position the pump so that the inlet tube is facing the LTR outlet tube. Torque the bolts to 25 Nm.



## COOLANT HOSES

### Intercooler Hose Circuit

Following are the four (4) 3/4" hoses (found in 1118-KIT4) that make up the intercooler circuit.



1. Intercooler pump inlet hose (1115-8D029)
2. LTR outlet hose (1118-8D030)
3. Intercooler pump-to-LTR hose (1115-8K236)
4. Intercooler reservoir inlet hose (1118-8D031)

**NOTE:** Route all intercooler hoses very carefully. It is critical for intercooler performance that these hoses are not kinked once installed into the vehicle.

Starting at the top of the engine, install the hoses as follows.

1. Connect the intercooler reservoir inlet hose (1118-8D031) to the hard line assembly (left-hand side).



2. Connect the other end to the side port on the degas bottle and secure with clamp (CT19X12-BO, found in 1118-TVSHWKG).



3. Connect the LTR outlet hose (1118-8D030) to the hard line assembly (right-hand side).



4. Route the LTR outlet hose (1118-8D030) from the intercooler down along the left radiator support and through the opening between the frame and radiator. Connect the hose to the lower port on the intercooler using one (1) 3/4" constant tension clamp (CT19x12-BO, found in 1118-TVSHWKG).



5. Route the intercooler pump inlet hose (1115-8D029) from the degas bottle outlet port (bottom port) to the inlet port of the intercooler pump by routing the hose along the radiator support at the left front of the engine. Route the hose through the opening between the frame rail and the radiator support. Connect the hose to the degas bottle using one (1) 3/4" constant tension clamp (CT19x12-BO).



6. Connect the intercooler pump inlet hose (1115-8D029) from the degas bottle outlet port to the inlet port on the pump using one (1) 3/4" constant tension clamp (CT19x12-BO) at each end.
7. Install one (1) 3/4" constant tension clamp (CT19x12-BO) onto each end of the intercooler pump-to-LTR hose (1115-8K236). Install the hose onto the pump outlet and onto the LTR inlet; position the clamps to secure the hose.



8. Connect the intercooler pump electrical jumper harness (1318-8W501) to the pump. Then, using a zip tie, secure the harness to the transmission cooler line, along with the harness for the electric cooling fan, at the center of the front crossmember.

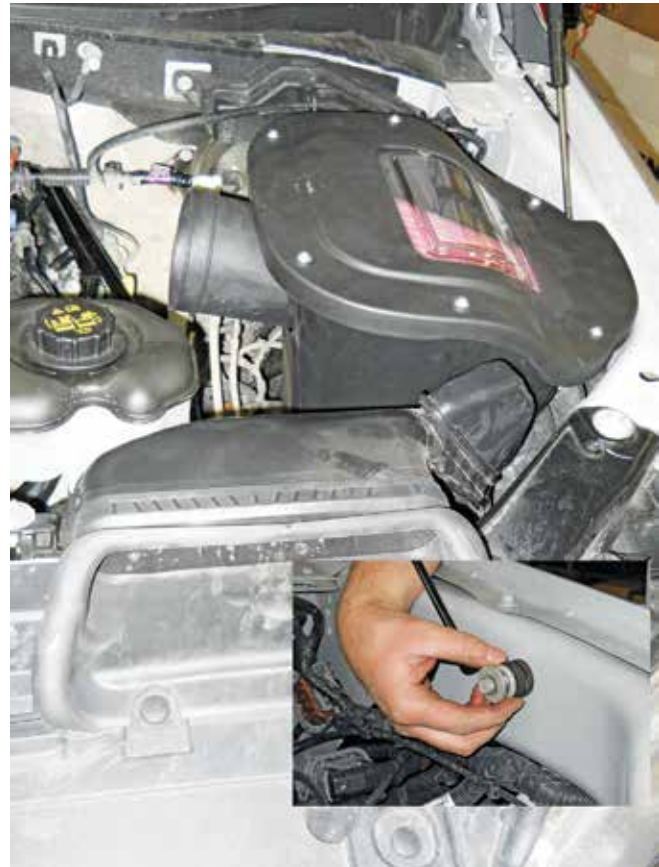

2. Install the new clean air tube assembly (1115SC-9B660) into position between the throttle body and the MAF tube. Torque the clamps on each end to 3 Nm.

9. Zip tie the hoses together.

### AIR INDUCTION SYSTEM

**NOTE:** When the clean air tube is installed, you will need to move and adjust the RH heater hose.

1. If not already done, reinstall the OEM mounting bolt and rubber isolator. Place the new ROUSH air box and OEM dirty air duct assembly in position on the vehicle. Align and slide the edge slot of the air box into the rubber isolator and secure the assembly in place with the two (2) original pushpins at the front of the dirty air duct.





3. To accommodate the new clean air tube, the RH heater hose must be repositioned. Clip the zip tie and pull out the push pin.



5. Connect the PCV fresh air inlet line to LH cam cover and the larger fitting (left) on the clean air inlet tube. It will likely be necessary to rotate and adjust the position of the PCV tube on the LH cam cover to make the connection.



6. Connect the brake booster line to the smaller fitting (right) on the clean air tube.



4. Move the RH heater hose over towards the battery until there is clearance for the air tube. Zip tie the heater hose back in place.

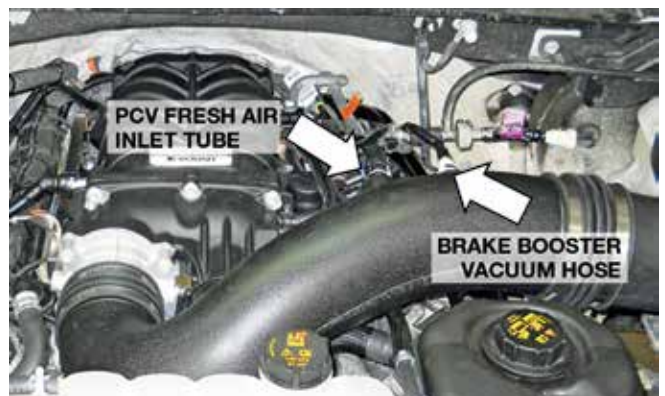

### SECTION E - FRONT BUMPER COVER REMOVAL

1. Release the tabs and remove the front license plate bracket (if equipped).
2. Remove the outer bumper cover pieces. (They are held on with clips.)



3. Remove the center section of the bumper cover. **(NOTE: The engine block heater cord may need to be zip tied out of the way.)**



4. There are two (2) options to allow airflow to the LTR.
  - a. Option 1: Purchase a front bumper cover from a 2018 Ecoboost F150.



- b. Option 2: Cut the center section out of the bumper cover to allow airflow to the LTR.



5. Reinstall the center bumper cover followed by the outer bumper covers.

### SECTION F – FINAL ASSEMBLY

1. Fill the engine cooling system (using a proper coolant mixture) to the marked level on the radiator degas bottle. Make sure the radiator petcock is closed tightly.
2. Using the same coolant mixture, fill the intercooler system through the degas bottle. The coolant should be approximately one inch below the top of the cap. Install the degas bottle cap (9C3Z-8101) and tighten when full.

**IMPORTANT:** Both coolant systems can trap a large amount of air. It is very important to verify that the air is purged and that coolant is flowing properly through both systems. ROUSH recommends vacuum filling both systems to properly evacuate the trapped air.

3. Inspect all underhood wiring harnesses for potential interference issues. Use zip ties to safely position the harness away from any areas of concern.
4. If the vehicle is not flashed yet refer to the PCM Flashing section. **DO NOT ATTEMPT TO START THE VEHICLE IF THE PCM IS NOT EQUIPPED WITH A ROUSH CALIBRATION. OPERATING THE ENGINE WITHOUT THE RECALIBRATED PCM WILL RESULT IN ENGINE DAMAGE OR FAILURE AND WILL VOID THE WARRANTY.**
5. Re-install the battery terminal connections by connecting the positive (+) cable first then connecting the negative (-) cable.
6. Reconnect the fuel pump control module electrical connector located above the spare tire on the frame.
7. Place the PCM warning sticker (R0700008-10, found in 1118-TVSHWK) above the PCM on the cowl of the vehicle.



8. The belt routing diagram (1318-6E072, found in 1118-TVSHWK) is to be placed on the underside of the hood, on the driver side, opposite of the factory Vehicle Emission Control Information decal.



9. Place the fuel door decal (13109A095, found in 1118-TVSHWK) on the backside of the fuel door. With the supercharger system installed, the vehicle is no longer E85 compatible. If your vehicle has a Flex-Fuel badge, it is recommended that this also be removed at this time.



10. Place the die cut tape (1116-9033) to the fuel filler cover (1116-9034). Clean the existing cover and stick the new cover over the top. Parts are found in 1118-TVSHWK.





- Place the “Premium Fuel” clear decal with white lettering (R07110004-11) on the instrument cluster bezel, on the flat area below the small center gauges as shown.

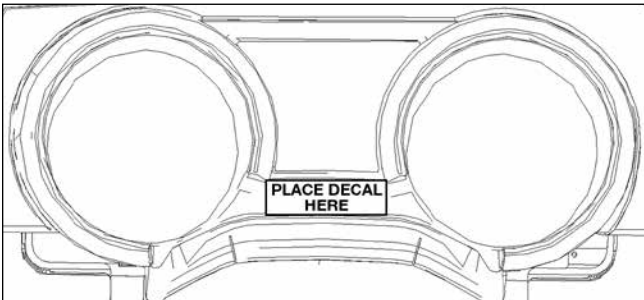

- Clean the oil fill cap and install the 5W50 sticker (1318-5W50ST) to the cover. Parts found in 1118-TVSHWKF.



**Congratulations**, you can now go enjoy your new ROUSHcharged 5.0L F-150.

### PCM FLASHING

- If equipped with a SAE J2534 pass-through device, refer to the RDT-CALIM manual included in the CALKIT for PCM flashing. The RDT-CALIM manual will guide you through the ROUSH Diagnostic Tool (RDT) software installation process and the ROUSH PCM flashing procedure. OPERATING THE ENGINE WITHOUT THE RECALIBRATED PCM WILL RESULT IN ENGINE DAMAGE OR FAILURE AND WILL VOID THE WARRANTY.
- Once the PCM has been successfully recalibrated, start the engine and check for unusual noises, dash service lights, and unusual operation. If problems are detected, immediately stop the engine or vehicle, diagnose and repair the problem.

### APPENDIX A – HYDROCARBON TRAP

1. Locate the stock airbox. Remove the Hydrocarbon Trap from the lid by either Drilling out / Cutting off the four corners of the plastic welds holding on the stock hydrocarbon trap. Note: Drill bit size 1/4" (Fraction) or 7 mm (Metric). BE CAREFUL TO NOT DRILL THRU THE HYDROCARBON TRAP.



2. Carefully remove the hydrocarbon Trap from the stock Ford airbox lid.



3. Transfer this hydrocarbon trap onto the Roush airbox lid as shown. Make sure the four corners of the hydrocarbon trap align with the Roush airbox lid pins, push the hydrocarbon trap onto the Roush airbox lid.



4. Using one Round Push Nut (94800A816) found in the Air Induction Hardware kit and place one onto each of the four pins with prongs facing upwards.



5. Using an 8mm socket to push and secure the hydrocarbon trap onto the Roush airbox lid as shown.

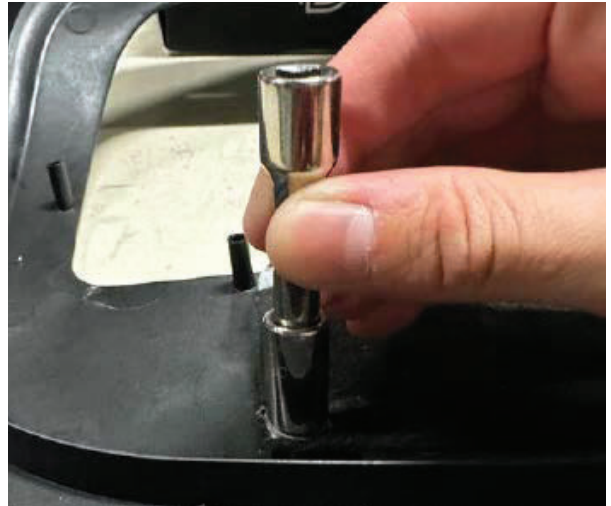

6. Repeat steps 4-5 for the other 3 pins.
7. Make sure the hydrocarbon trap is secured in place as shown, test it by hand, it should be secure onto the Roush airbox lid.

