



PREMIUM FUEL REQUIRED

2011+ 5.0L Mustang Phase 2 ROUSHcharger Kit

P/N: 421390 (1313-P2CAL)

Installation Instructions



Application:

2011+ Ford Mustang GT with 5.0L 4-Valve Engine w/ Manual Transmission
2011+ Ford Mustang GT with 5.0L 4-Valve Engine w/ Automatic Transmission

Important Notes:

- Before installing your Mustang ROUSHcharger Kit, please read the installation manual and verify that all items are present. . If you are missing hardware or have any questions, please contact ROUSH Performance at 1-(800) 59-ROUSH.
- Premium fuel (91 octane or higher) is required to prevent “spark-knock” or detonation under certain operating conditions.
- The use of fuel additives (i.e. octane boosters) is not recommended. There is a possibility that these chemicals can damage your engine and cause drivability issues with your vehicle.
- Operating your engine without the Roush PCM recalibration will result in engine damage or failure and will void your warranty.
- Installation of this kit voids the 3 yr / 36,000 mile limited ROUSH Powertrain warranty.**



ROUSH[®]
P E R F O R M A N C E

PREMIUM FUEL REQUIRED

TABLE OF CONTENTS

PACKING LIST FOR 421390 (1313-P2CAL) ROUSHcharger KIT 3

EQUIPMENT AND SUPPLIES REQUIRED 7

GLOSSARY OF TERMS 8

INFORMATION ABOUT THE SUPERCHARGER BYPASS OPERATION 8

IMPORTANT INFORMATION REGARDING SUPERCHARGER NOISE 8

LIMIT OF LIABILITY STATEMENT 9

SAFETY PRECAUTIONS 9

SECTION A – DISASSEMBLY 10

SECTION B – MODIFICATIONS 23

 Brake Booster Hose Modification- (Manual Transmission) 23

 Brake Booster Hose Modification- (Automatic Transmission) 24

 Front Cover Modification 26

 TPS/ETC Wiring 30

 Canister Purge Valve Wiring 33

 Intercooler Pump Wiring 35

 Air Charge Temperature (ACT) Wiring 37

 Mass Air Flow (MAF) Wiring 39

 Knock Sensor Orientation Adjustment 41

 Changing the Factory Spark Plugs 41

SECTION C – SUBASSEMBLY 42

 Intercooler Low Temperature Radiator (LTR) 42

 Intake Manifold Build Up 45

 Throttle Body Spacer Assembly 46

 Fuel Rail Assembly 49

 Airbox Assembly 50

SECTION D – INSTALLATION 54

 Intercooler Reservoir Mounting 54

 Automatic Transmission Oil Cooler Hose 55

 Intercooler Radiator Assembly Mounting 58

 Electric Water Pump, Mounting Bracket and Hoses 59

 Induction Resonance Tube Delete Grommet 64

 Intake Manifold and Supercharger Installation 65

 FEAD Assembly 72

 Coolant Hoses 72

 Air Induction System 81

SECTION E- Final Assembly 85

 PCM Flashing 88

APPENDIX A – SIDE SHIELD MODIFICATIONS 88



ROUSH
P E R F O R M A N C E

PREMIUM FUEL REQUIRED

PACKING LIST FOR 421390 (1313-P2CAL) ROUSHCHARGER KIT

Part Ref	Description	Part Number	Qty
	Air Induction	---	
1	ROUSH Airbox Assembly	1313-9643	1
2	MAF Tube	R07060101	1
3	Air Filter	997-495	1
4	Clean Air Tube Asy	1313-9B659	1

Part Ref	Description	Part Number	Qty
	Hardware Kit A – Induction	1313CAK-HWKA	1
5	Hose Clamp	R07130014	1
6	Hose Clamp	R07130015	1
7	Edge Seal	39-211-12	1
8	Edge seal (9.5")	R07130026-13-9.5	1
9	Edge seal (12")	R07130026-13-12	1
10	Edge seal (4")	R07130026-13-4	2
11	Mounting Bracket – MAF Tube to Air Box	R07130010	1
12	Bolts M6x1.0x14 – Mntg Brkt to MAF & Airbox	N605771	3
13	Vacuum Fitting – S/C Bypass	383004-S	1
14	Vacuum Fitting – Brake Booster (3/8 x 3/8)	P2233A	1
15	Vacuum Cap – 3/8	CS2575	1
16	Nut – M6x1.0 Airbox to Fan Shroud	W520412	1
17	MAF Bolts (M4x0.7x10 Torx)	R07130007	2

Part Ref	Description	Part Number	Qty
18	Fuel Charging Assembly	13119H487	1
19	Supercharger Assembly	1311H-6F066	1
20	Fuel Rail	13119F792	1
21	Throttle Body Assembly – Dual 60 mm	R07060150	1
22	Throttle Body Spacer Assembly	13119A589	1
23	Fuel Injector Kit	M-9593-LU47RSH	1
24	Fuel Injector Clip	1311-9C995	8
25	S/C Pulley – 6K Ø85mm	1313-6K85	1
26	Spark Plug - 0.9mm gap (CYFS12YP)	BL3E-12405-BA	8



ROUSH
P E R F O R M A N C E

PREMIUM FUEL REQUIRED

Part Ref	Description	Part Number	Qty
	Hardware Kit B – Fuel Charging	1311-TVSHKB	1
27	Gasket – Throttle Body To Spacer	R07060153	1
28	Gasket – Throttle Body Spacer to Supercharger	R07060152	1
29	Bolt – Throttle Body to Spacer & Supercharger (M6 x 32.5)	R18020009	8
30	Bolt – Intake to Cylinder Heads (M6 x 40)	R18020004	6
31	Bolt – Supercharger to Intake (M8 x 53)	N808130	10
32	Bolt – Evaporative Emission Canister Valve to Spacer (M6 x 35.5)	N808429	2
33	Bolt – S/C Pulley (M6 x 16)	W500013	6

Part Ref	Description	Part Number	Qty
	FEAD	---	
34	Upper FEAD Bracket	1314-8B653U	1
35	FEAD Tensioner Bracket Assembly	13118B603	1
36	Serpentine FEAD Belt	6K2085-8620	1

Part Ref	Description	Part Number	Qty
	Hardware Kit C – FEAD	13116066FRTHKC	1
37	Pulley - Idler B/S 76mm	953045	2
38	Bolt – Idler (M8 x 28 large washer)	R18020060	2
39	Bolt – Upper FEAD to Engine and Intake (M8 x 84)	W704752	2
40	Bolt – Lower Bracket to Upper Bracket (M8 x 41)	W705128	1
41	Bolt – Upper FEAD to Engine (Bottom) (M8x1.25x60)	111116346	3
42	Bolt – Lower Bracket to Engine (M8 x 120)	N811329	2

Part Ref	Description	Part Number	Qty
	PCV & Vacuum	---	
43	PCV Fresh Air Inlet	13116758	1
44	PCV Purge Hose with Bubbler	13116K817	1
45	Evaporative Emission Canister Purge Valve Line	BR3V-9G271	1
46	7/32" Vacuum Hose – Supercharger Bypass (Length = 105mm)	R18140001	1
47	Vacuum Harness – Supercharger Bypass Reference	7R3V-9E498	1

Part Ref	Description	Part Number	Qty
	Wiring	---	
48	Electrical Jumper – Intercooler Pump	13118W501	1
49	ACT Wiring Harness	1311-12A690	1
50	TPS Extension Harness	131114A595	1
51	Canister Purge Valve Extension Harness	13119G866	1
52	MAF Extension Harness	131112B579W	1
53	Intercooler Jumper Harness (use if Pump is FS00057975)	PT00045528	1



ROUSH
P E R F O R M A N C E

PREMIUM FUEL REQUIRED

Part Ref	Description	Part Number	Qty
	Hardware Kit D – Wiring	1313-HWKD-AA	
54	Nut - I/C Relay Mounting (M6)	W520412	2
55	Zip Tie with Fir Tree Clip (Wire Harness to Front Cover)	156-00329	1

Part Ref	Description	Part Number	Qty
	Decals / Labels & Instructions	---	
56	Decal – 2011 Belt Routing Diagram	13116E072	1
57	Decal – Premium Fuel Only (Cluster)	R07110004	1
58	Decal – Premium Fuel Only (Fuel Door)	13109A095	1
59	Decal- PCM	R07100008	1
60	Warranty Card	1150-TVSCALWC	1
61	Limited Base Warranty	1150-LBW	1
62	Installation Manual	1313-P2CALIM	1
63	Label – Spark Plug Warning	PT00045644	2

Part Ref	Description	Part Number	Qty
	Intercooler System	---	
64	Degas Bottle	13108D080	1
65	Intercooler Electric Water Pump with Bracket	392022009	1
66	Bracket - Intercooler Pump Mounting	1313-8C419	1
67	Intercooler Low Temp Radiator (LTR)	13108K229	1
68	3/4" Hose – Degas Bottle Inlet	13118D031	1
69	3/4" Hose – Intercooler Pump Inlet	13108D029	1
70	3/4" Hose – Intercooler Pump to LTR	13108K236	1
71	3/4" Hose – Intercooler LTR Outlet	13118D030	1
72	3/8" Hose – Engine Bottle Degas Hose	13118276	1
73	3/4" Hose Sleeve – 424mm Heater Hoses	1311-18K579SLV	2
74	Intercooler Pump Mounting P Clip	8863T95	1
75	Intercooler Pump Foam	1318-8D082	1
76	BOLT - M8 X 1.25 X 29 HEX FLANGE DOGPOINT FULLY THREADED 8.8	W500224-S437	1
77	Intercooler Bracket (Only for Pump PN: FS00057995)	PT00045433	1



ROUSH
P E R F O R M A N C E

PREMIUM FUEL REQUIRED

Part Ref	Description	Part Number	Qty
	Hardware Kit E – Intercooler System	13116066FRTHKE	1
78	Bracket – LTR Upper LH	13108K242	1
79	Bracket – LTR Upper RH	13108K243	1
80	Bracket – LTR Lower LH	13108K244	1
81	Bracket – LTR Lower RH	13108K245	1
82	Rubber Grommet – LTR Isolator	R07060107	4
83	Sleeve – LTR Isolator	R07060108	4
84	Degas Bottle Cap	9C3Z-8101-B	1
85	Clamps – 3/4" Hoses (Constant Tension)	CT19x12-BO	8
86	Bolt – Long Bumper Bolts (M8 x 35)	R18020007	2
87	Bolt – LTR to Brackets (4) & I/C Pump to Bracket (2) (M8 x 25)	W500224	6
88	Nut – I/C Pump Mounting Bracket to Bumper Bolts (M8)	W520413	4
89	Bolt – Degas Bottle Mounting & LTR Bracket to Chassis (M6 x 22)	R18020057	4
90	J-Clip – Degas Bottle & Pump Bracket Mounting (M6 Short)	N623332	1
91	NVH Isolator – I/C Pump to Bumper Beam	13108Z419	1
92	NVH Isolator – I/C Pump to LTR	13108Y419	1
93	Nut – I/C Wiring Relay to Chassis (M6)	W520412	1

Part Ref	Description	Part Number	Qty
	HARDWARKE KIT G - Automatic Transmission	1313-HWKG-AA	1
94	Hose - Trans Cooler (26" Length)	1312-7R081	1
95	Worm Clamp - Trans Cooler Line Joint (3/4")	5407K58	1
96	Convolute/Loom - Split, black, 3/4in	1312-TRANSCONV	1
97	Zip tie - 6" LENGTH	KTI--78070	7

Part Ref	Description	Part Number	Qty
	CALKIT	1311-P2CALKIT	1
98	ROUSH Diagnostic Tool Flash Manual	RDT-CALIM	1
99	Optional Roush PCM Flash	PCM-FLASHDOC	1
100	Flash Voucher Card	P1311-P2	1

Part Ref	Description	Part Number	Qty
101	Shield- Pulley Bearing Dust Cover	PT00040547	3

If you are missing any items, please call us toll free at 1-800-59-ROUSH.



PREMIUM FUEL REQUIRED

EQUIPMENT AND SUPPLIES REQUIRED

- 1/4" and 3/8" Drive Ratchets with Extensions
- Metric and Standard Socket Sets (short and deep recommended)
- Metric and Standard Wrench Sets
- 3/8" Drive Torque Wrench (7-35 ft-lb range)
- 6" Scale, Tape Measure, or Other Measuring Device
- Assembly Lubricant (White Lithium Grease or Petroleum Jelly)
- Electrical Tape
- Sharp Knife or Razor Blade
- Medium Strength Thread Locker – Loctite 242 (blue) or equivalent
- T-20 Torx Bit Screwdriver or Socket
- 5/16" Drill Bits and Drill motor
- Coolant (meeting Factory Ford specification for 2011 Mustang GT)
- 1/2" Drive Ratchet or Breaker Bar
- Short Phillips-head Screwdriver
- 5/8" Fuel Line Removal Tool
- Solder and Soldering Iron
- Heat Gun or Small Torch for Heat Shrink Tubing
- Tie Straps (Zip Ties)
- Trim Pad Tool (for pushpin removal)
- Fender Cover (2)
- 1/2" Transmission Line Removal Tool (Only for Automatic Transmission)



PREMIUM FUEL REQUIRED

GLOSSARY OF TERMS

ACT	Air Charge Temperature Sensor (From the factory, this function is integrated into the MAF sensor. With this kit, a separate ACT sensor is installed into the intake manifold)
ETC	Electronic Throttle Control
MAFS	Mass Air Flow Sensor
PCM	Powertrain Control Module (a.k.a. ECM, ECU, PCU, EEC)
PCV	Positive Crankcase Ventilation
TPS	Throttle Position Sensor
RDT	ROUSH Diagnostic Tool
VMV	Vapor Management Valve (aka Canister Purge Valve)

Breakout Point A place in an electrical harness where the wiring for an individual component leaves (breaks out of) the main harness to attach to an individual component.

INFORMATION ABOUT THE SUPERCHARGER BYPASS OPERATION

There is a great deal of misinformation about the function of supercharger bypass systems. The supercharger is a positive-displacement pump; that is, so long as it is rotating, it is always pumping air. During low demand or high vacuum operation (i.e. idle, deceleration, and light throttle cruise), the pumping action is undesirable as it creates unwanted heat and noise. The bypass circuit, when open, prevents any pressure buildup across the supercharger and allows air to circulate through the rotors, allowing the supercharger to “idle” freely during these conditions. This results in reduced noise, and by reducing heat buildup in the intake, significantly improves street and strip performance. As throttle demand increases, the bypass circuit is closed, resulting in full performance from the supercharger. The bypass circuit is never used to limit or control boost during full-throttle operation and defeating or altering the bypass function will not result in improved performance in any condition, and will result in poor drivability.

IMPORTANT INFORMATION REGARDING SUPERCHARGER NOISE

We understand that you may notice some noise variations from your supercharger. The majority of noises are completely normal and each supercharger can have a different noise signature. As superchargers are belt-driven by the engine, the engine’s torsional vibrations will cause the mechanical components of the supercharger, including gears, shafts, and bearings, to make noise. Noise levels can also be influenced by both the supercharger and ambient air temperatures, especially in cold environments. As temperatures and engine speeds vary, the characteristics of the noise may change. It’s important to note that each unit may produce slightly different sounds due to these variables. Generally speaking, these noises do not affect the performance, reliability, or longevity of your supercharger and are not cause for concern. If you have any concerns, please feel free to reach out to our team.



PREMIUM FUEL REQUIRED

LIMIT OF LIABILITY STATEMENT

The information contained in this publication was accurate and in effect at the time the publication was approved for printing and is subject to change without notice or liability. Roush Performance Products reserves the right to revise the information presented herein or to discontinue the production of parts described at any time. Installation of this kit voids the 3 yr / 36,000 mile ROUSH Powertrain warranty.

SAFETY PRECAUTIONS

STOP! CAREFULLY READ THE IMPORTANT SAFETY PRECAUTIONS AND WARNINGS BEFORE PROCEEDING WITH THE INSTALLATION!

Appropriate disassembly, assembly methods and procedures are essential to ensure the personal safety of the individual performing the kit installation. Improper installation due to the failure to correctly follow these instructions could cause personal injury or death. Read each step of the installation manual carefully before starting the installation.

- ! Always wear safety glasses for eye protection.
- ! Place the ignition switch in the OFF position.
- ! Always apply the parking brake when working on the vehicle.
- ! Block the front and rear tire surfaces to prevent unexpected vehicle movement.
- ! Operate the engine only in well-ventilated areas to avoid exposure to carbon monoxide.
- ! Do not smoke or use flammable items near or around the fuel system.
- ! Use chemicals and cleaners only in well-ventilated areas.
- ! Batteries can produce explosive hydrogen gas which can cause personal injury. Do not allow flames, sparks or flammable sources to come near the battery.
- ! Keep hands and any other objects away from the radiator fan blades.
- ! Keep yourself and your clothing away from moving parts when the engine is running.
- ! Do not wear loose clothing or jewelry that can be caught in rotating or moving parts.





PREMIUM FUEL REQUIRED

SECTION A – DISASSEMBLY

The following section will guide you through the disassembly of the stock components. Special care should be taken to label fasteners and parts that are taken off during this procedure since many will be reused:

1. Cover both fenders with fender covers to protect the vehicle finish.
2. Release the fuel system pressure (**NOTE:** The following procedure is taken directly from the Ford Service Manual).

 **WARNING:** Fuel in the fuel system remains under high pressure even when the engine is not running. Before working on or disconnecting any of the fuel lines or fuel system components, the fuel system pressure must be relieved. Failure to do so can result in personal injury.

 **WARNING:** Do not smoke or carry lighted tobacco or open flame of any type when working on or near any fuel-related components. Highly flammable mixtures are always present and can be ignited, resulting in personal injury.

- a. Disconnect the Fuel Pump Control Module electrical connector.
NOTE: The Fuel Pump Control Module is located in the spare tire stowage compartment.

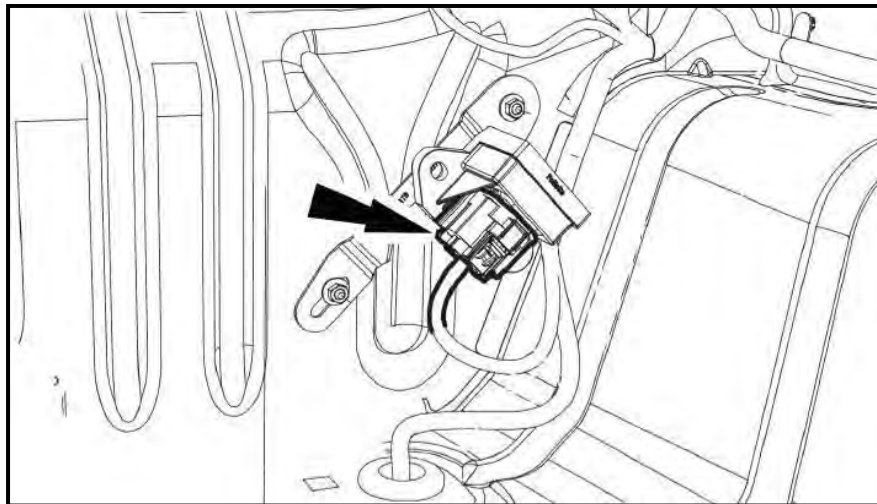

- b. Start the engine and allow it to idle until it stalls.
- c. After the engine stalls, crank the engine for approximately 10 seconds to make sure the fuel injector supply manifold pressure has been released.
- d. Turn the ignition switch to the OFF position.



PREMIUM FUEL REQUIRED

3. Using an 8mm wrench, disconnect the (-) negative and (+) positive connections to the battery.
4. Remove the (8) push pin retainers by pulling the center pin and remove the radiator trim cover.

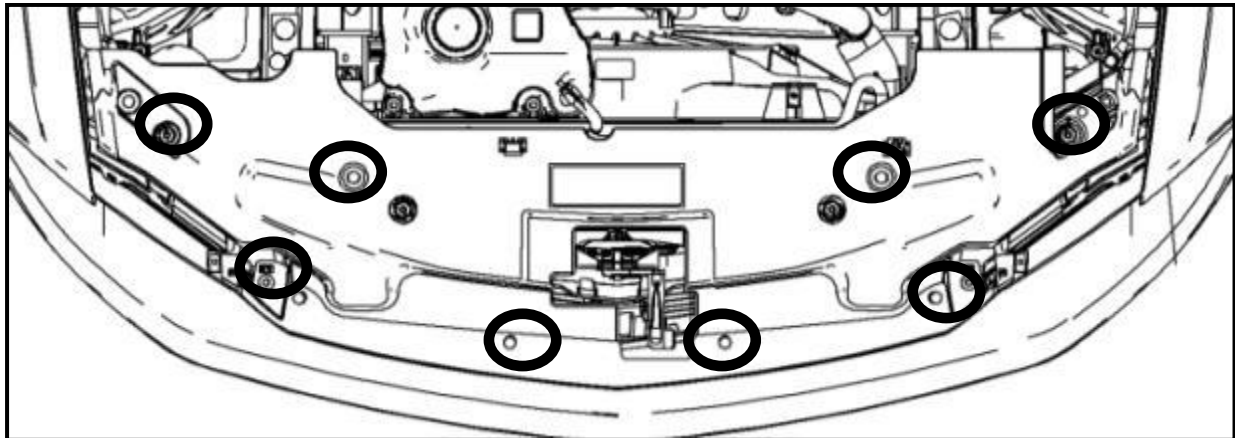

Before continuing, refer to the CALKIT included with your ROUSHcharger kit. Determine the PCM flash method you will be using. If performing the PCM flash yourself or at a preferred ROUSH dealer, proceed to step 6. If sending the PCM to ROUSH for a ROUSH performed PCM flash, continue with step 5.

5. Disconnect the 3 PCM (Powertrain Control Module) connectors by lifting the grey levers over the connector back shell and lifting the connectors from their sockets. Remove the PCM by removing two 10mm bolts and pulling the PCM forward and lifting out of the engine compartment. Follow the instructions on the next page as soon as possible to help minimize the amount of time you are without a PCM.

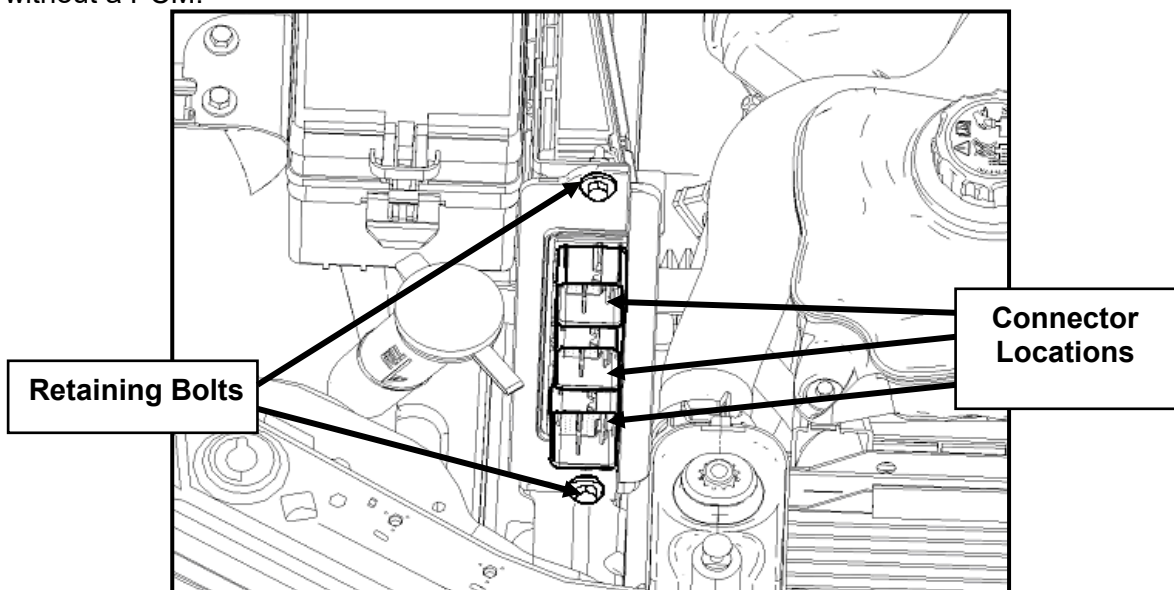

Important: Be sure to write your VIN number and phone number (in case we need to contact you for additional vehicle information) on the PCM using a permanent marker.



PREMIUM FUEL REQUIRED

INSTRUCTIONS FOR RETURNING THE PCM TO ROUSH FOR CALIBRATION

Outlined below are the instructions for returning your stock powertrain control module (PCM) to Roush Performance Products so we can install our calibration to make the engine run properly with the new components. **Please complete the “Base Limited Warranty Registration” card and include it, along with the PCM, the “Optional Roush PCM Flash” request document, and the “Voucher Card”.** Once we receive your PCM, we will reprogram and return it back to you the same day for next-day delivery. **Operating your engine without our calibration will result in engine damage or failure and will void all warranty.**

Note: It is important to reinstall the PCM in the vehicle it came from to prevent setting a trouble code and having to relearn the anti-theft code which can only be performed using specialized Ford Service Bay tools.

- If you haven't already done so, write your vehicle identification number (VIN) and phone number on the PCM using a permanent marker.
- Using bubble wrap, or another appropriate packing material, wrap and package the PCM to help prevent it from being damaged during shipping.
- Place the wrapped PCM in an appropriate shipping box.
- **Complete the “Warranty Registration Card” (1150-TVSCALWC),**
- **Complete the “Optional ROUSH PCM Flash” request document (PCM-FLASHDOC) and attach the flash “Voucher Card” (P1311-P2) to the document.**
- **Include the “Warranty Registration Card”, “Optional ROUSH PCM Flash” document, and the “Voucher Card” in the shipping box, along with the PCM.**
- Ship the PCM and contents to:

**Roush Performance
ATTN: PCM FLASH
12170 Globe Street
Livonia, MI 48150**

Upon receipt of the PCM, a customer service representative will contact you to arrange payment. Once you receive your ROUSH flashed PCM, reverse step 5 for PCM installation.



PREMIUM FUEL REQUIRED

6. Raise the front of the vehicle using the Ford recommended lifting points and place onto safety stands. With the tires lifted off of the ground, remove the front wheels. Remove the (3) forward Phillips-head screws from each front wheel liner. Using a Phillips-head screwdriver, turn the (5) inner fender push pins $\frac{1}{4}$ turn to release the centers. Remove the pushpins and then remove the forward inner fenders.
7. Remove the (3) lower close-out to radiator support screws (7mm socket). Remove the (2) upper bumper cover screws near the headlights (10mm socket). Remove the (4) front fender to bumper cover nuts inside the forward wheel well (10mm socket). Reach inside the front wheel wells and unplug the front turn signals. Lift the front bumper cover slightly and pull partially off of the vehicle. Unplug the fog lights and set the front bumper cover aside.
8. Remove the (4) push pins that retain the impact absorber to the front bumper beam and set the absorber aside.
9. Carefully remove the radiator / cooling module side shields that are mounted to the left and right hand side of the A/C Condenser. (See Appendix A) Note: The LH shield engages the air inlet system.
10. With the engine cool, remove the cap on the engine coolant degas bottle and drain the coolant using the petcock located on the lower passenger side of the radiator.

TIP: Connect a $\frac{3}{8}$ " hose to the drain fitting next to the petcock and run into a clean drain pan or bottle. Use a $\frac{3}{4}$ " wrench to open petcock and allow coolant to drain out of the fitting.

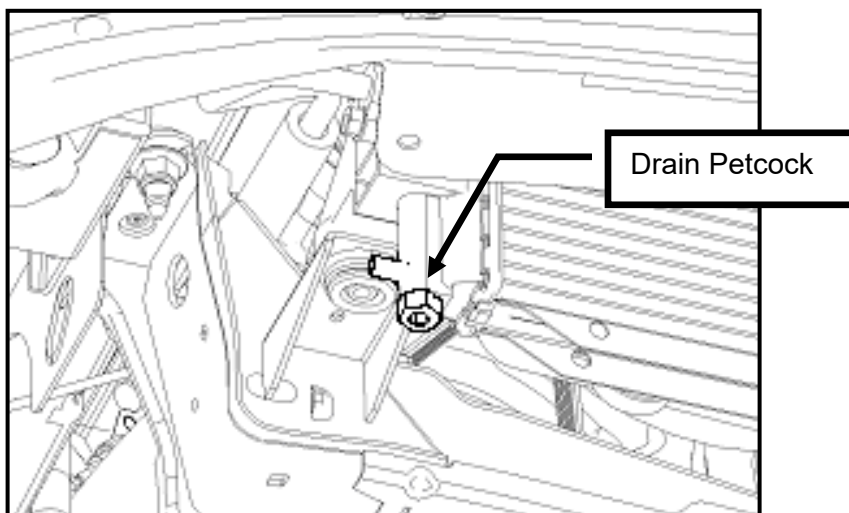



ROUSH[®]
P E R F O R M A N C E

PREMIUM FUEL REQUIRED

11. If equipped, remove the (4) nuts and the strut tower cross brace. Reinstall the (4) nuts and torque to 30-40 Nm. The strut tower cross brace cannot be reused after the supercharger has been installed.

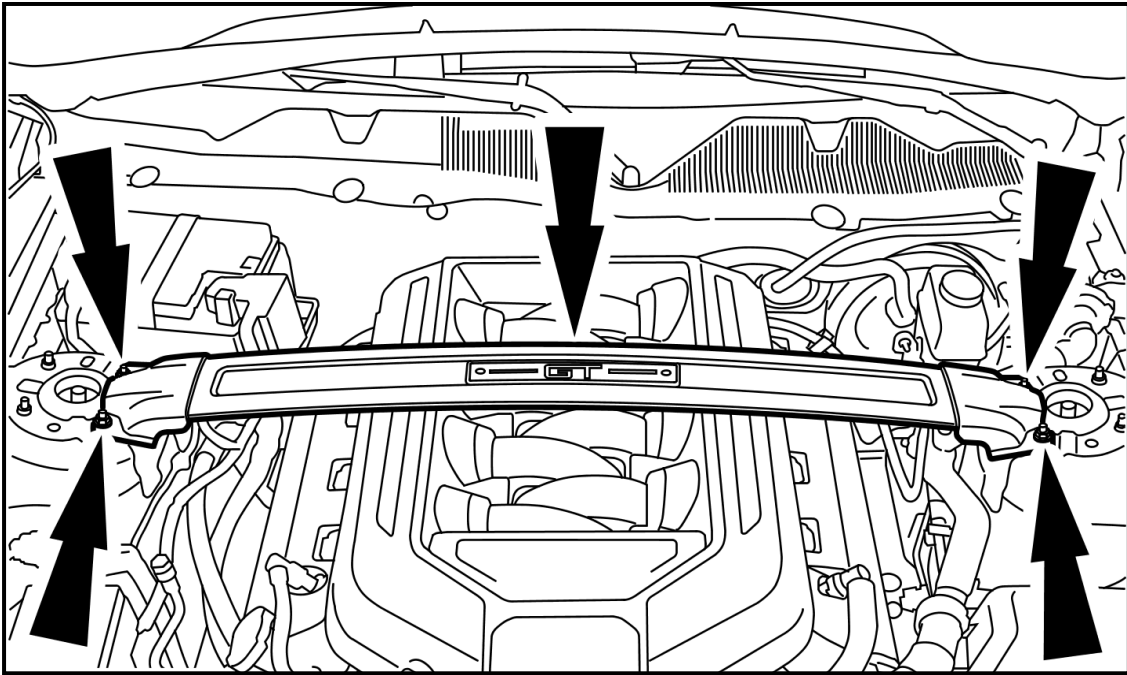

12. Remove the engine appearance cover. The cover cannot be reused after the supercharger has been installed.

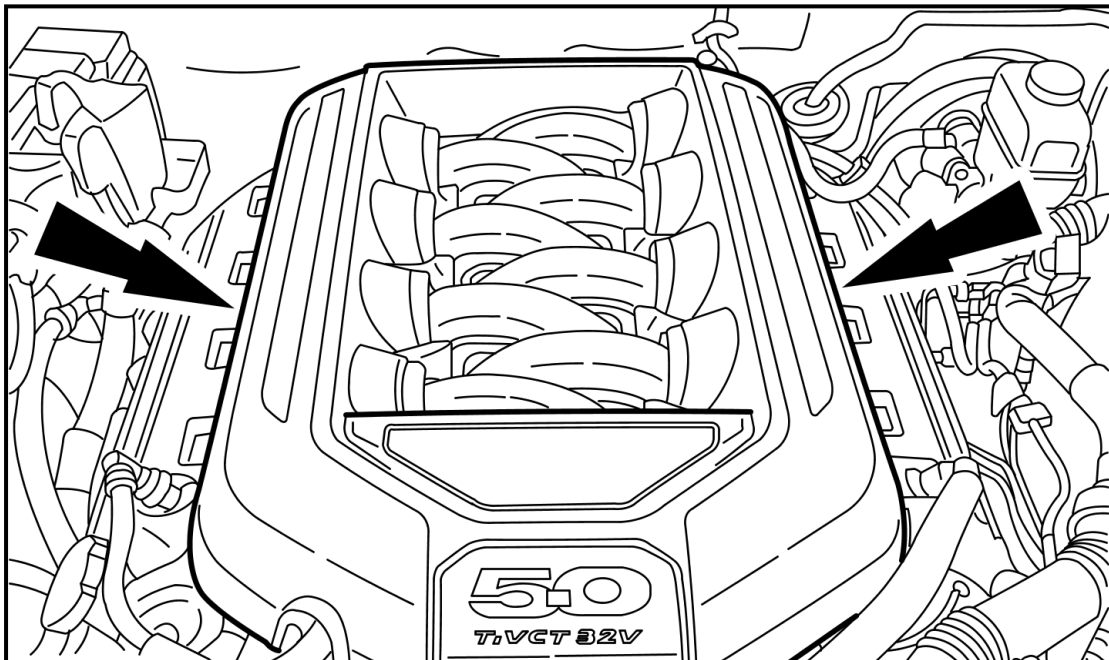



PREMIUM FUEL REQUIRED

13. Remove the M6 bolt that secures the induction resonance tube to the driver side fender near the cowl. Remove the tube from the cowl.

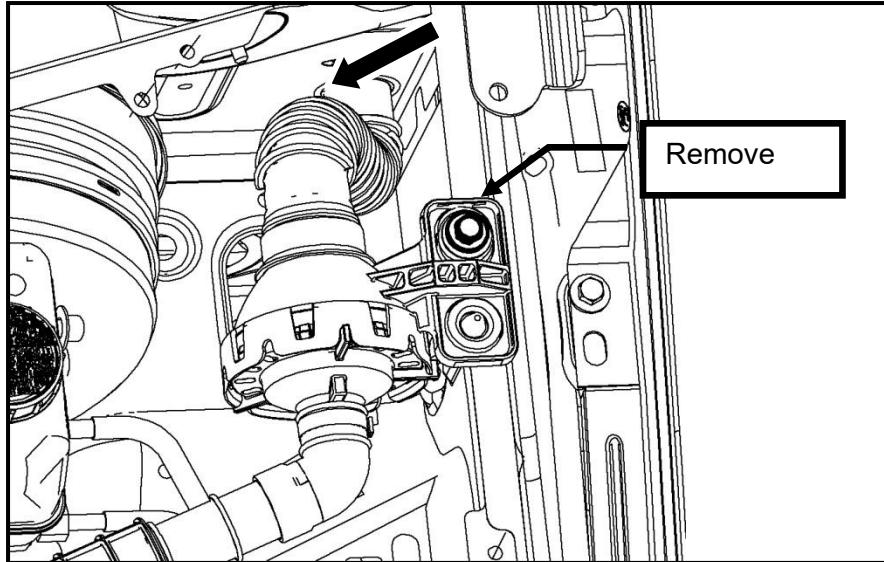

14. Disconnect the PCV Fresh Air Inlet tube from the left-hand cam cover and clean air tube. Remove the clean air tube from the throttle body and airbox. Remove the clean air tube and the induction resonance tube from the vehicle. Neither of these components will be reused.
15. Remove the MAF (mass air flow) sensor connector by pulling the red locking tab back and pressing the black release tab. Release the locking tabs securing the upper airbox lid to the lower airbox. Disconnect the MAF wiring harness retainer from the front edge of the upper airbox lid and remove the lid from the vehicle. The airbox lid will not be reused.

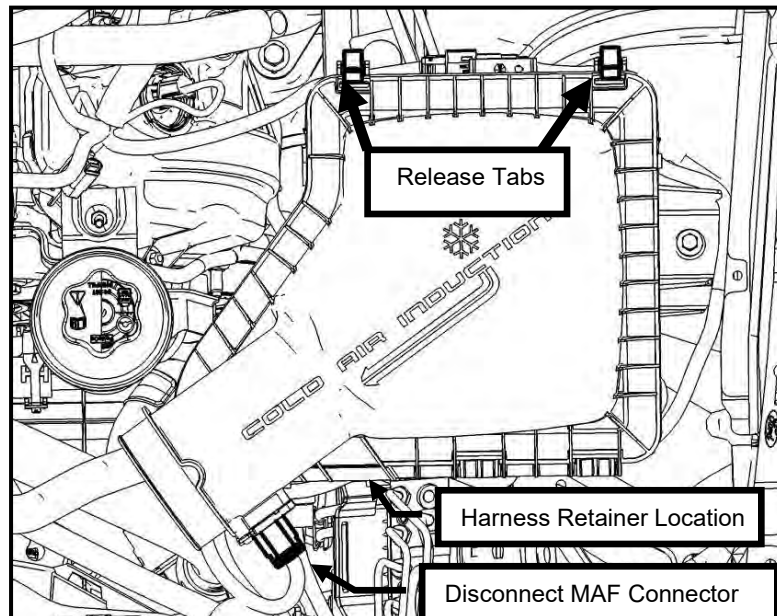



PREMIUM FUEL REQUIRED

16. Disconnect the throttle body electrical connector. (Pull the red locking tab back; press the black release tab to disengage the lock). Refer to #15 in figure shown below.
17. Disconnect the VMV (evaporative emission canister purge valve) tube and electrical connector. Remove the VMV tube retainer from the front left hand cam cover. Disconnect the remainder of the tube at the fitting located behind the inner fender below the brake booster. This tube will not be reused. Refer to #16 in figure shown below.
18. Remove the PCV Purge line from the intake manifold and right-hand cam cover. This line will not be reused. Refer to #17 in figure shown below.

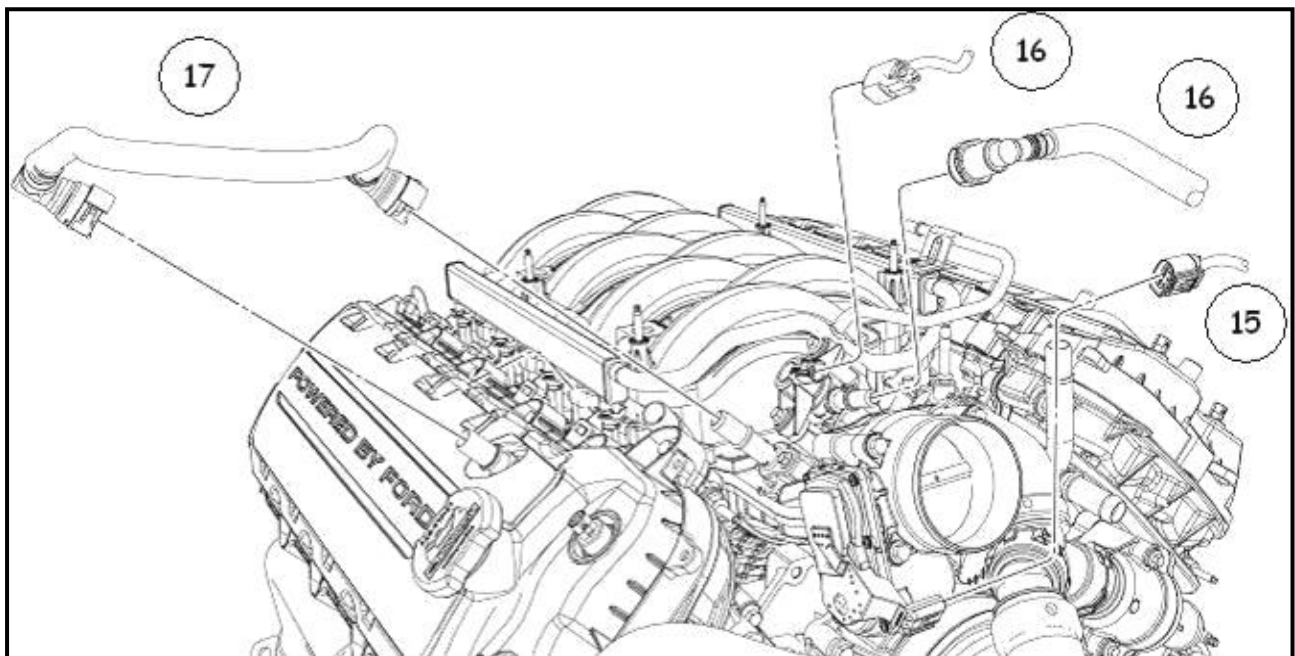

Procedures #15 - 17

19. Disconnect the fuel supply hose from the fuel rail. Refer to #18 in figure shown below.
20. Disconnect the brake booster vacuum hose from the intake manifold. This port is located directly behind the throttle body. Refer to #19 in figure shown below.



PREMIUM FUEL REQUIRED

20-a. Disconnect the brake booster vacuum hose and aspirator assembly from the vehicle and set aside. **(Auto Trans Only)**

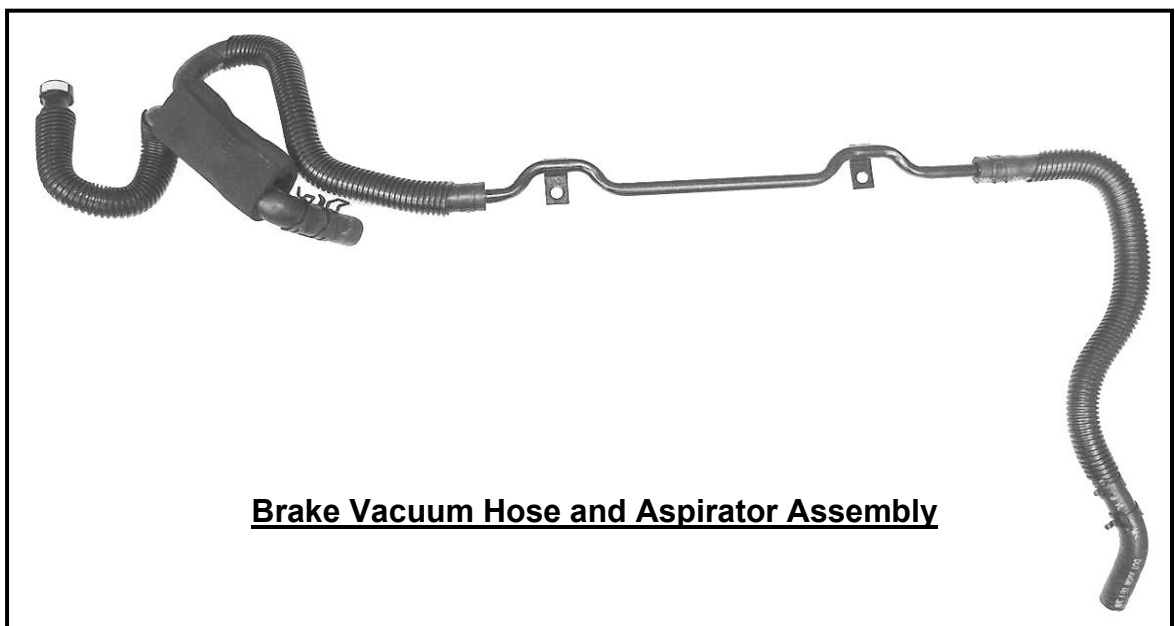
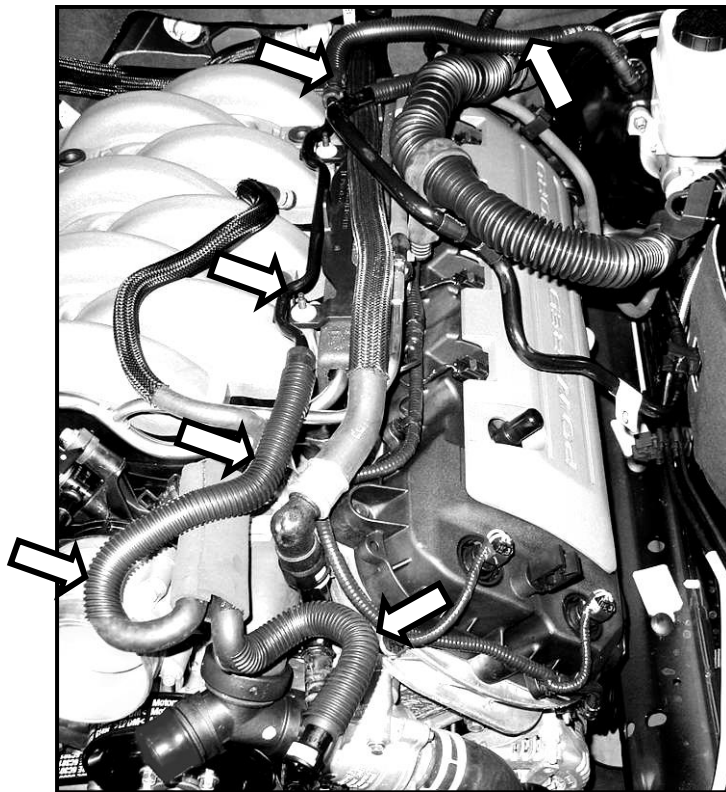

Brake Vacuum Hose and Aspirator Assembly



PREMIUM FUEL REQUIRED

21. Disconnect the heater feed and return hoses located at the front of both the LH and RH cylinder head intake flanges. Position these hoses aside by tucking them up underneath the edge of the hood near the windshield wipers. Refer to #20 in figure shown below.
22. Remove the (2) nuts and support bracket that retained the RH heater hose above the RH fuel rail. This hardware will not be reused. Refer to #21 in figure shown below.
23. Remove the steel section of the brake booster vacuum line from the rubber hose at the joint found at the rear of the intake manifold. Discard the steel and forward rubber section of this assembly as it will not be reused. Refer to #22 in figure shown below.
24. Remove the (2) nuts and support bracket that retained the LH heater hose above the LH fuel rail. This hardware will not be reused. Refer to #23 in figure shown below.

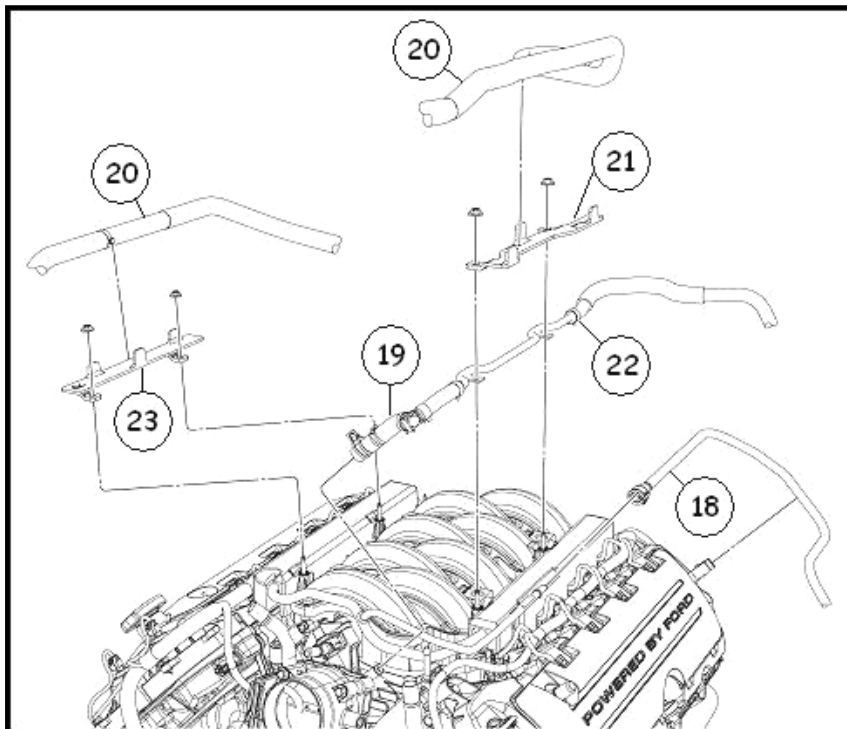

Procedures #18 - 23

25. Remove the 3/8" engine coolant degas hose from both the engine and the degas bottle.
26. Carefully detach the (4) wiring harness retainers from the rear of the intake manifold. The two "outer" clips will be reused once the new manifold is installed to retain the harness.
27. Remove and discard the LH and RH fuel rail insulators. Disconnect the (8) fuel injector electrical connectors.
28. Remove the (4) fuel rail bolts. **These bolts will be reused.** **NOTE:** It is not necessary to remove the fuel rail from the intake manifold assembly.



PREMIUM FUEL REQUIRED

29. Remove the (6) intake manifold mounting bolts and remove the intake manifold and fuel rail assembly from the vehicle. This hardware will not be reused.

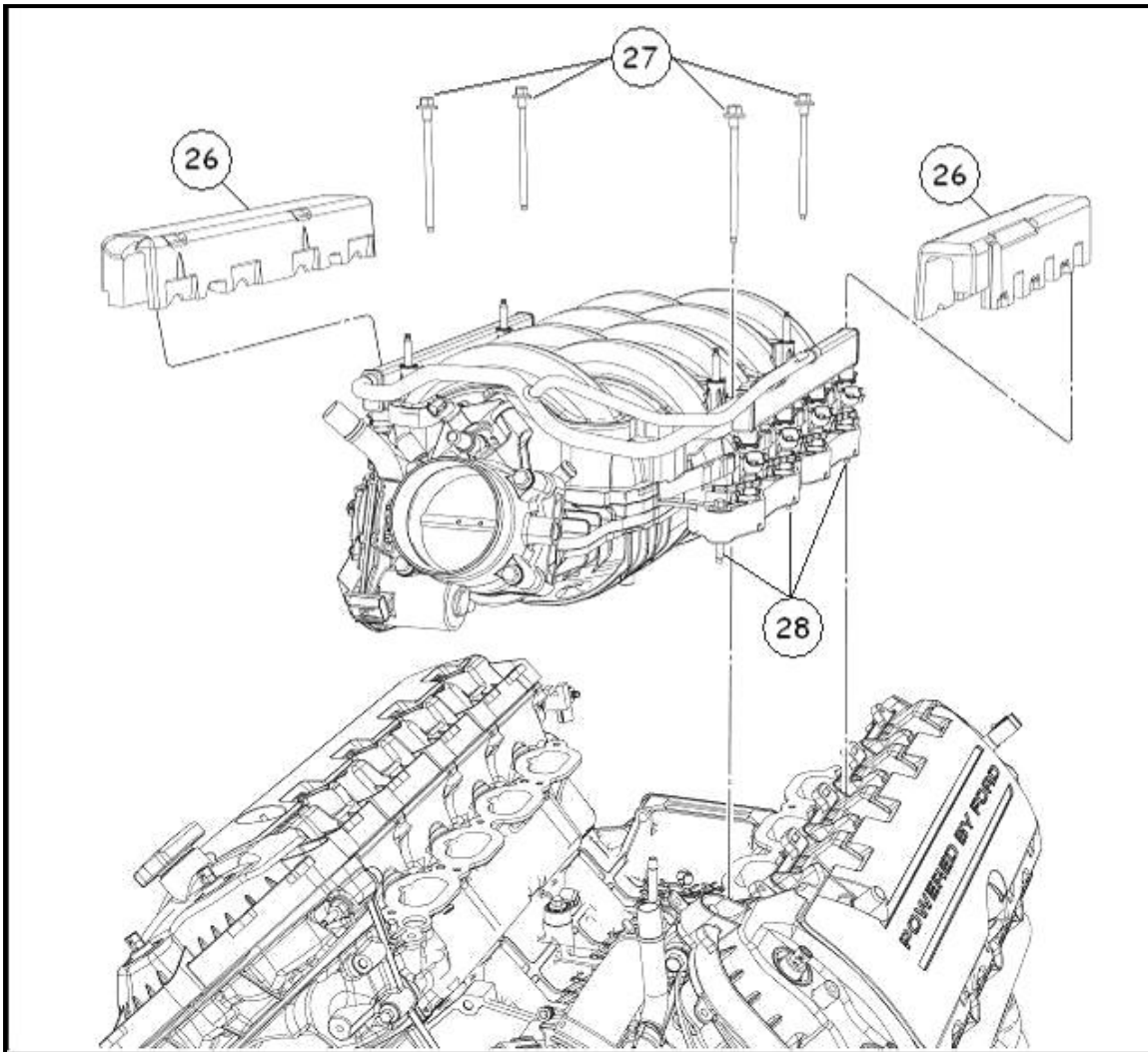

Procedures #26 – 28

30. Clean the intake mounting surfaces and apply tape over the open intake ports to prevent engine contamination.
31. Remove the engine coolant degas bottle.



ROUSH[®]
P E R F O R M A N C E

PREMIUM FUEL REQUIRED

32. Remove the Front End Accessory Drive (FEAD) belt. Rotate the FEAD Tensioner counter-clockwise to release the belt tension and remove the belt.

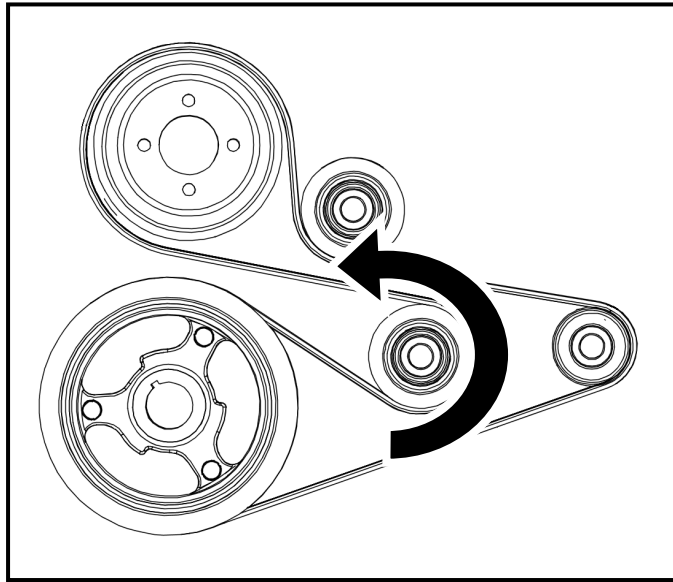

33. Remove the (4) bolts securing the Water Pump Pulley to the engine
34. Cut and remove the A/C compressor belt. Discard belt.
35. Remove the upper radiator hose.
36. Remove the electric fan and shroud assembly from the vehicle.



ROUSH
P E R F O R M A N C E

PREMIUM FUEL REQUIRED

37. Disconnect and remove the transmission oil cooler lines support bracket from the cooling fan module. Un-crimp the bracket from the transmission cooler lines and discard the bracket and isolator. Disconnect the transmission oil cooler line at the quick connect fitting. Use the 1/2" transmission line connector removal tool.

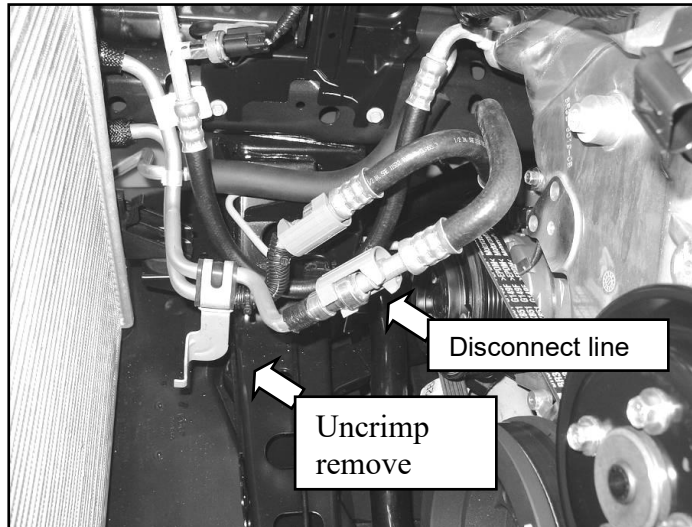

38. Remove the four fasteners holding the AC condenser to the cooling module and shift the AC condenser forward and down. Do not disconnect any AC lines





ROUSH[®]
P E R F O R M A N C E

PREMIUM FUEL REQUIRED

39. Disconnect the transmission cooler hose from the transmission oil cooler. Remove the hose clamp for reuse.



40. Unclip the engine electrical harness retention clips that retain the engine harness to the top corners of the right hand (passenger side) front cover.



PREMIUM FUEL REQUIRED

SECTION B – MODIFICATIONS

The following section will guide you through the required modifications of existing components and build up of the assemblies used to complete the installation. With the exception of the wiring modifications and intercooler pump bracket mounting, all of this work can be performed away from the vehicle.

BRAKE BOOSTER HOSE MODIFICATION- (MANUAL TRANSMISSION)

1. Remove the factory brake booster hose that is still connected to the booster.

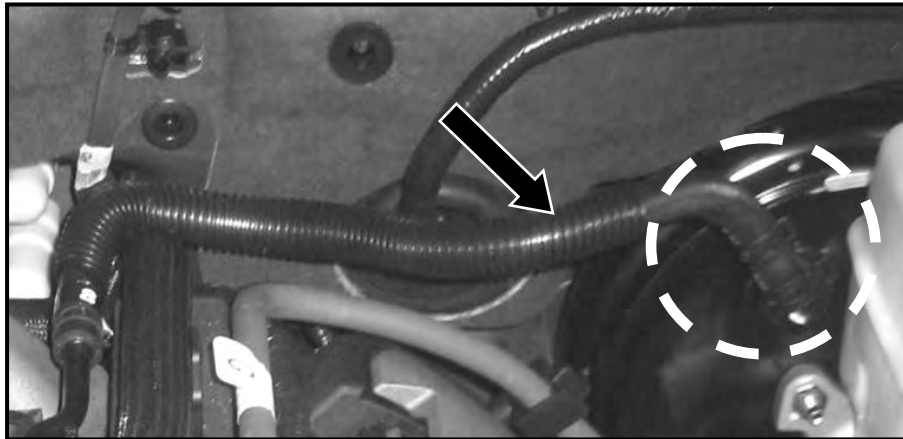

2. Cut 30mm off of the end of the hose that was connected to the brake booster and 40 mm off of the opposite end that was connected to the steel tube, as shown below. Place a piece of tape or a mark on the end of the hose that was cut by 30mm. This end of the hose will connect to the throttle body spacer upon re-assembly.





PREMIUM FUEL REQUIRED

BRAKE BOOSTER HOSE MODIFICATION- (AUTOMATIC TRANSMISSION)

1. Retrieve the brake vacuum hose and aspirator assembly and place it on a work bench.
2. Disassemble the vacuum hose assembly and lay it out on the bench as shown.

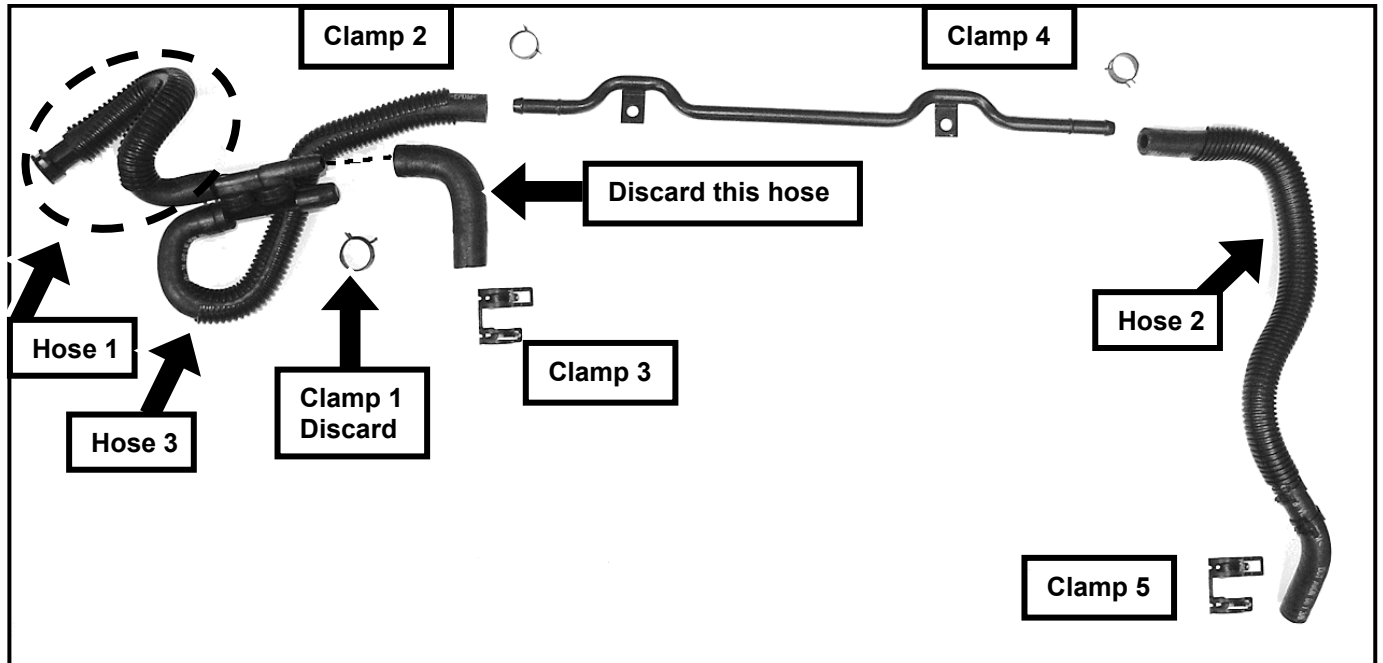

3. Remove convolute and discard. Modify Hose 1 as shown.

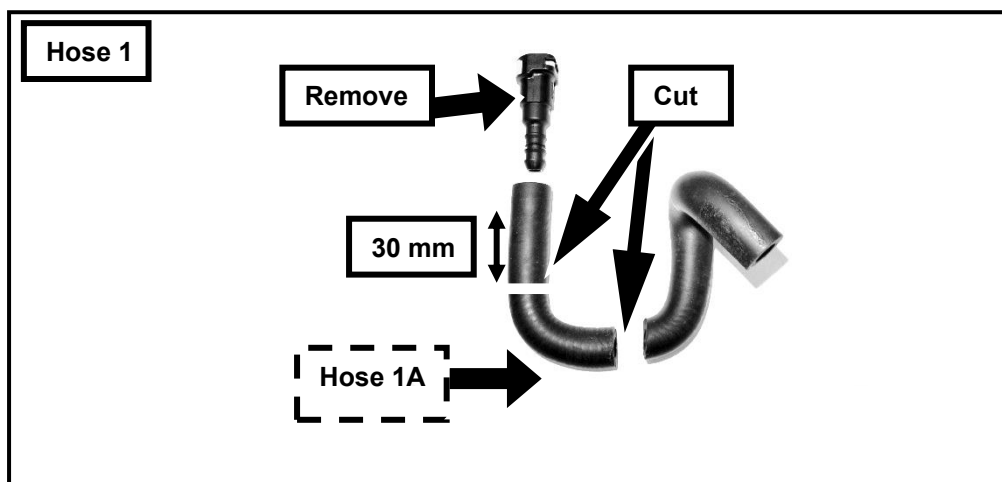



PREMIUM FUEL REQUIRED

4. Modify Hose 2 as shown.

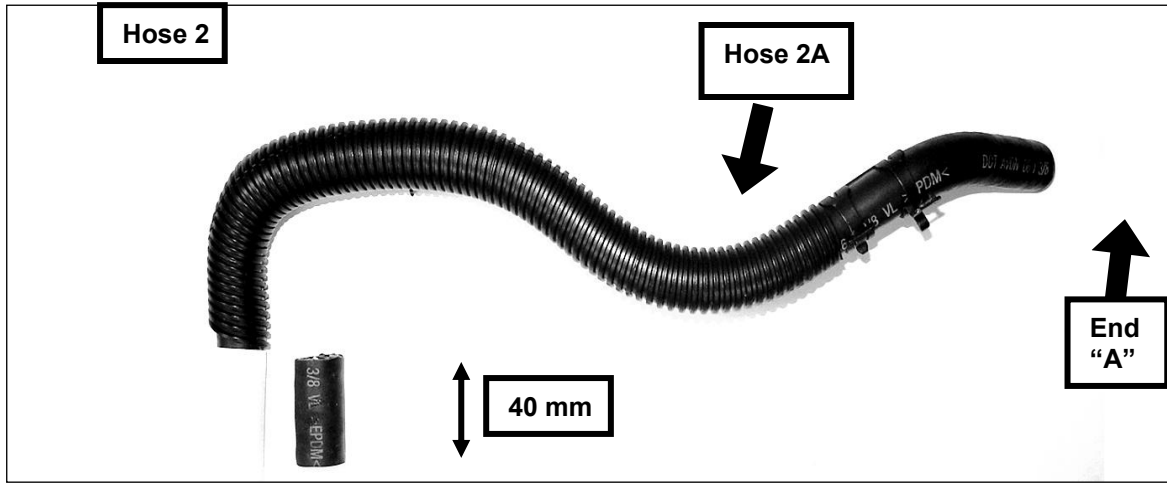

Brake Vacuum Hose and Aspirator Assembly

Attach End "A" of Hose 2A to the aspirator assembly as shown. Attach Hose 1A as shown.

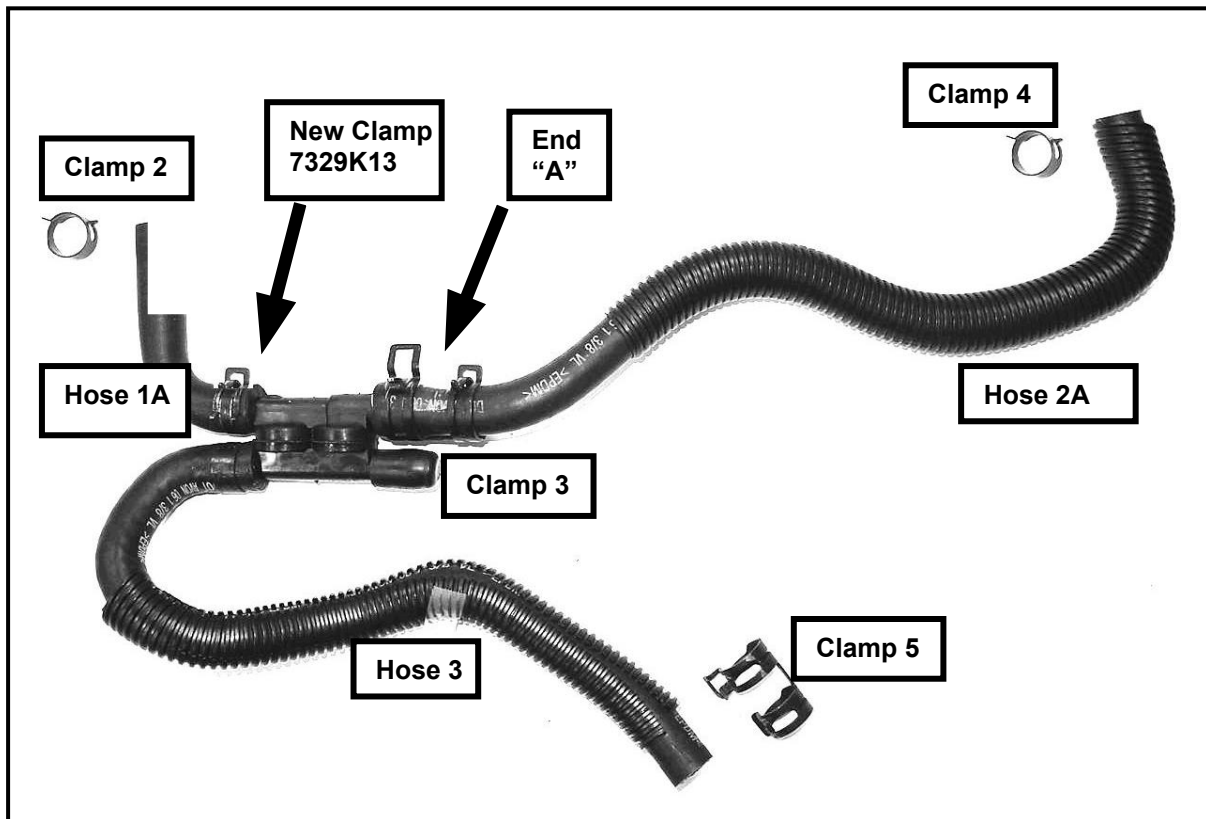



PREMIUM FUEL REQUIRED

FRONT COVER MODIFICATION

1. Using a grinder or cut off wheel, modify the front cover in the areas shown. The two bosses located at A and B need to be reduced in height such that they are flush, or lower than the height of the nearby rib structure. The portions of the rib structure C, D, E and F need to be removed completely (cut just above flush to the surface of the front cover). Be careful not to remove too much material in these areas as permanent damage to the front cover could occur. The boss located at G needs to be reduced in height and cut in half.

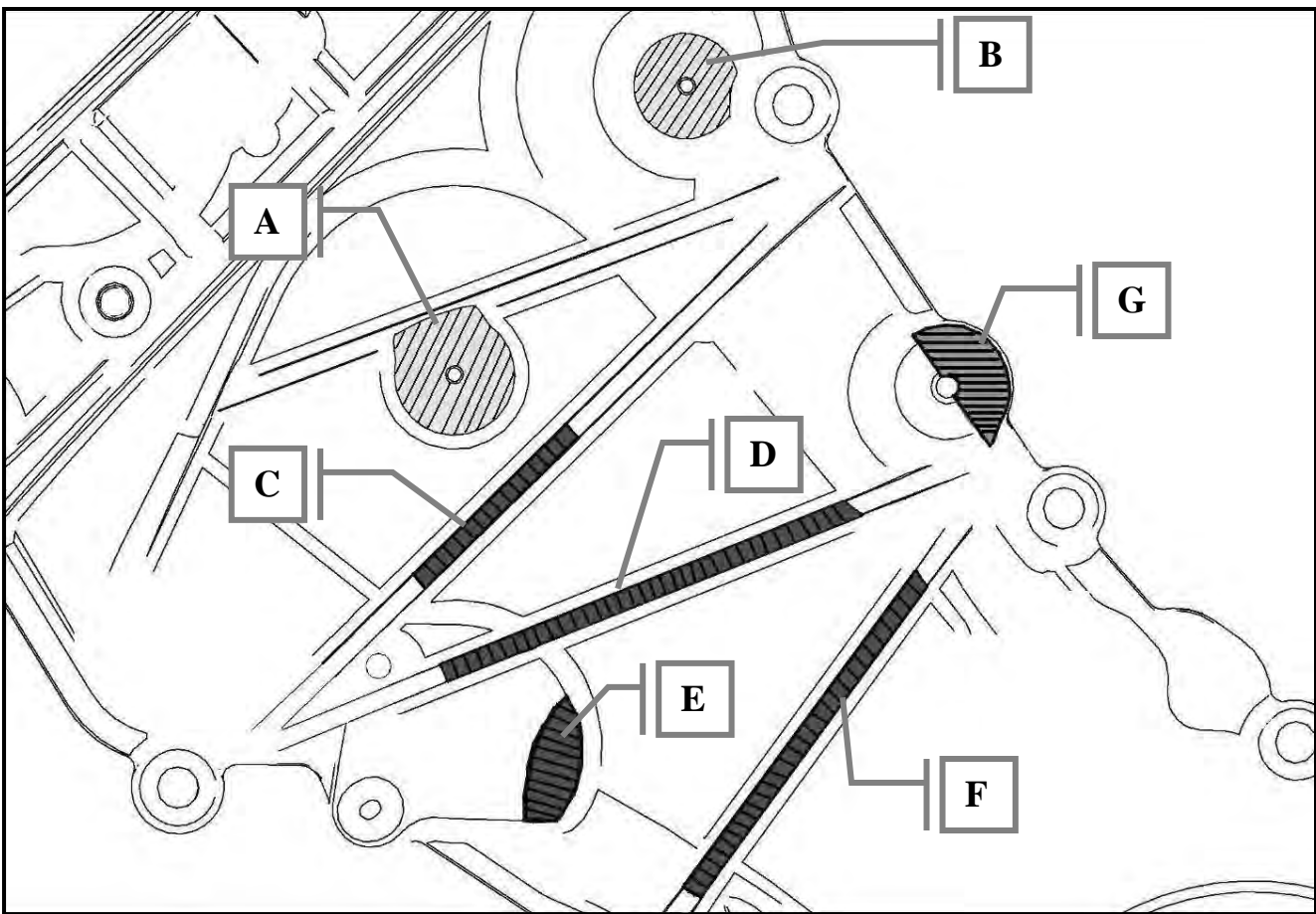



ROUSH[®]
P E R F O R M A N C E

PREMIUM FUEL REQUIRED

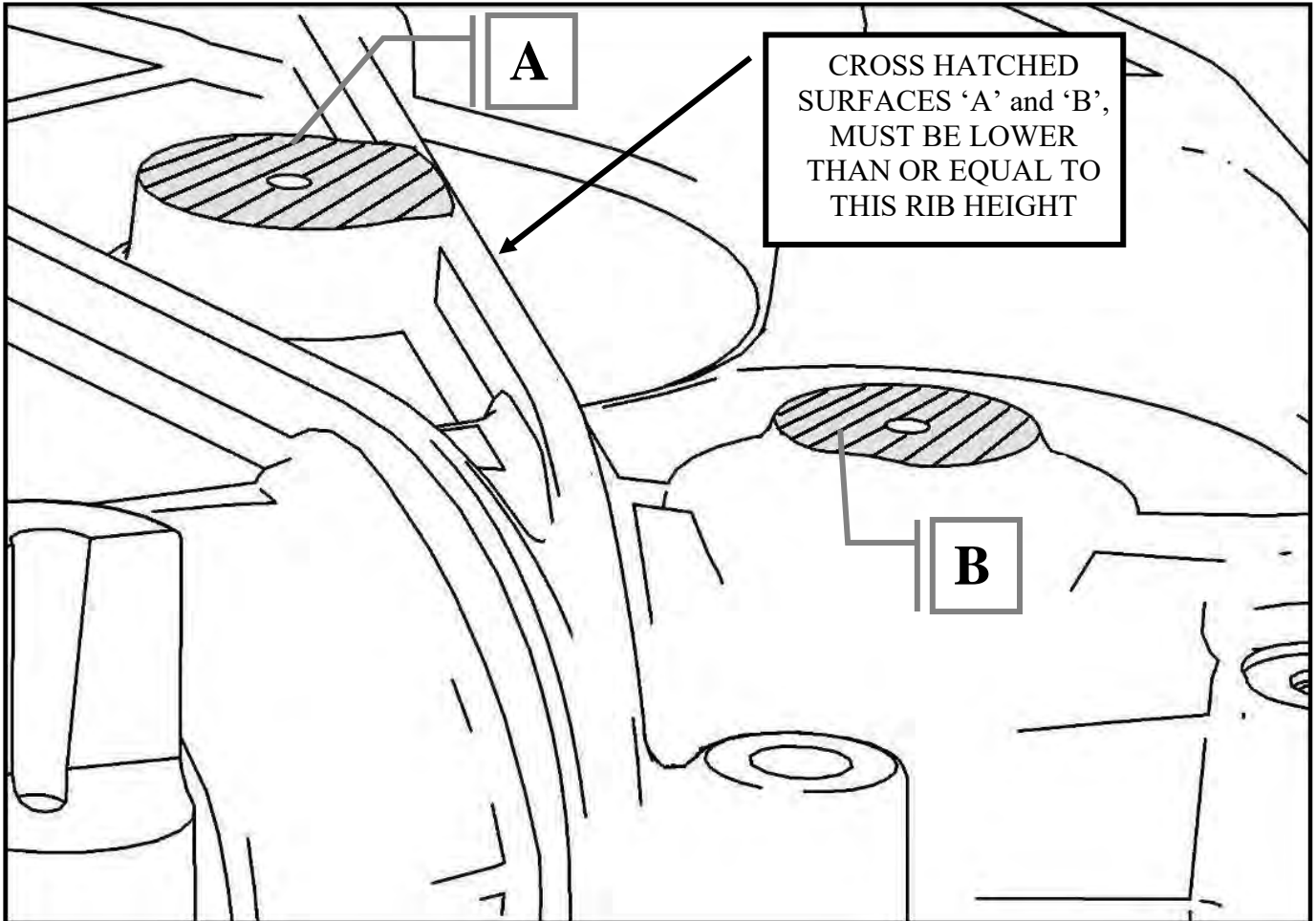



ROUSH[®]
P E R F O R M A N C E

PREMIUM FUEL REQUIRED

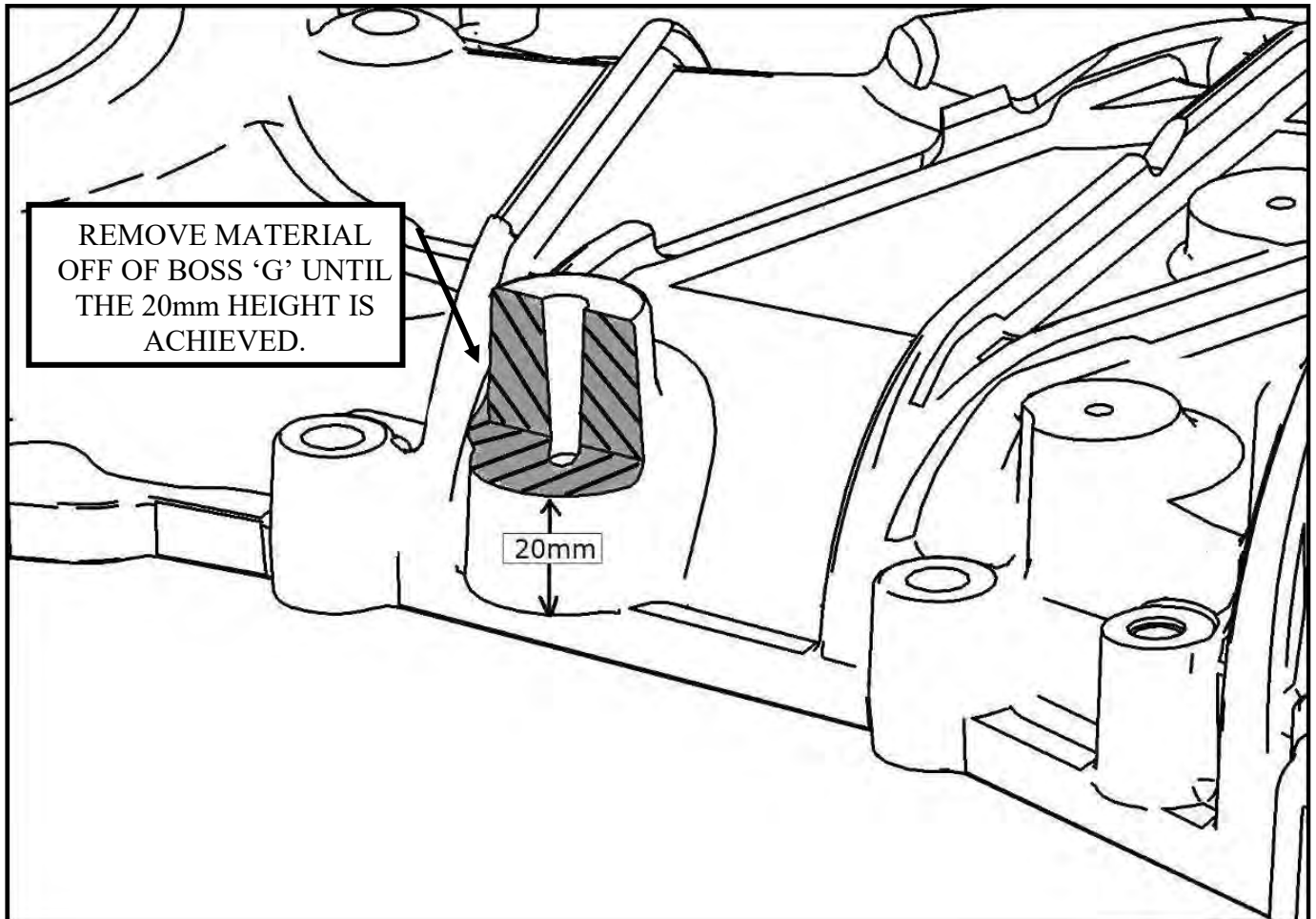



PREMIUM FUEL REQUIRED

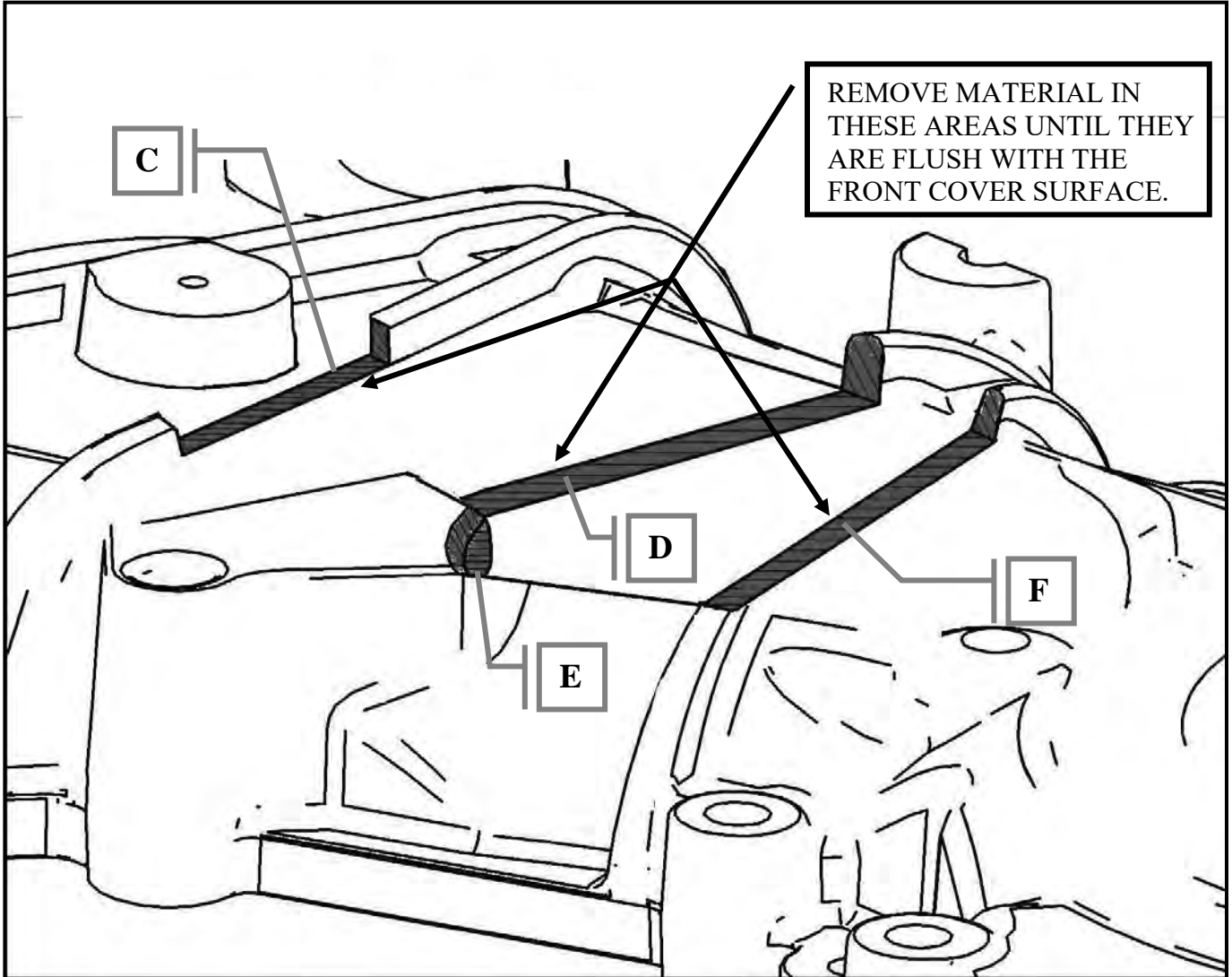



ROUSH[®]
P E R F O R M A N C E

PREMIUM FUEL REQUIRED

TPS/ETC WIRING

1. If you have not already done so, remove the upper radiator cover by removing the 8 push pins.



2. **NOTE: IF THE WIRE HARNESS INCLUDED IN THE KIT IS 131114A595-BA SKIP STEPS 2-4 DO NOT DEPIN NOT NECESSARY!**

Locate the Throttle Position Sensor (TPS) connector and harness at the front of the passenger side cylinder head. Use a proper de-pinning tool to remove the connector from the harness.

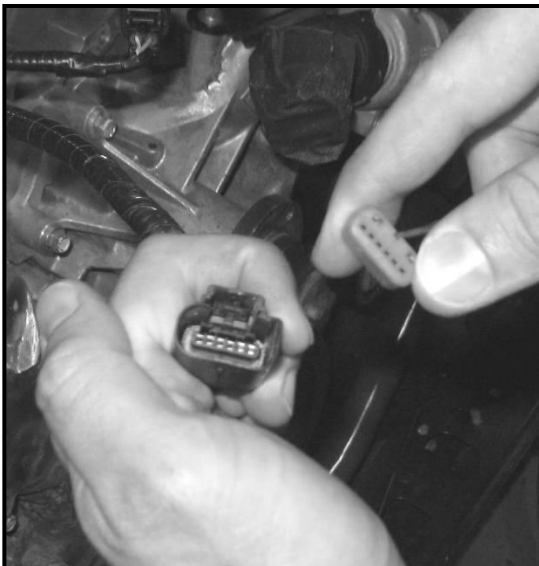



PREMIUM FUEL REQUIRED

3. Depress the locking tab and separate the “empty” female 1 x 6 connector from the new TPS/ETC Extension harness (131114A595). It will be used in the next step.

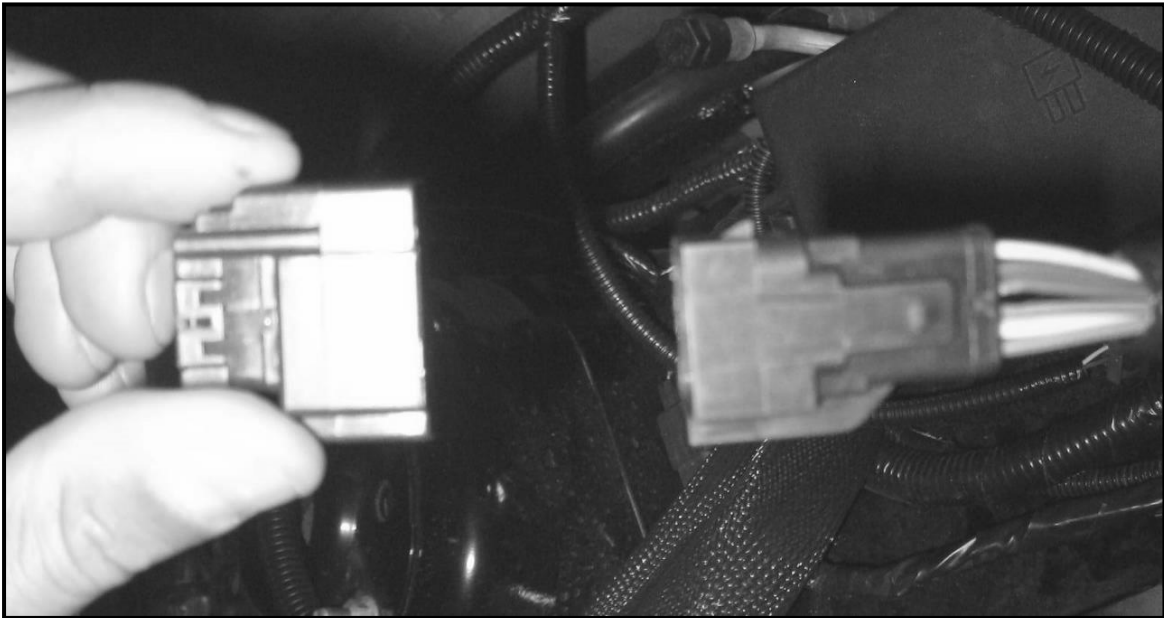

4. Populate the new connector such that the yellow with violet wire is in position 1, the blue with green wire is in position 2, the brown wire is in position 3, the blue with orange wire is in position 4, the yellow wire is in position 5 and the green with violet wire is in position 6. Install the red plastic lock into the connector to secure the wires in place.

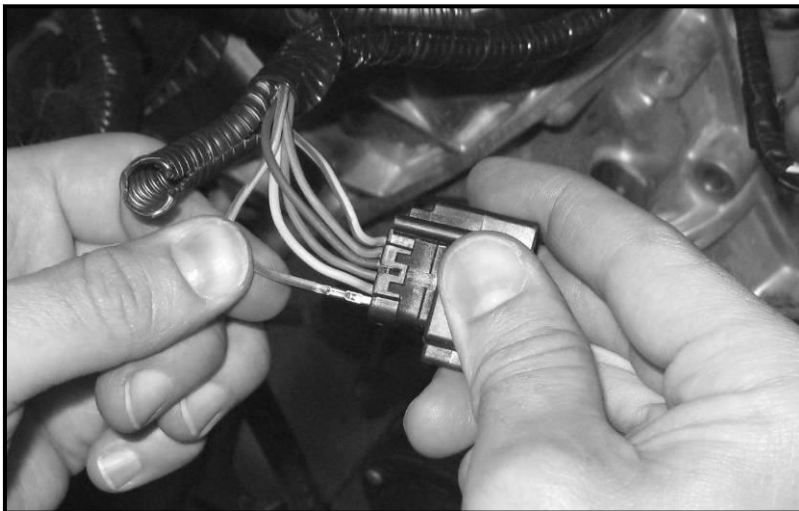



PREMIUM FUEL REQUIRED

5. Connect the TPS/ETC extension harness to the newly installed connector. The wire colors on each side of the connector pair should align. Route the harness along the main wiring harness to the rear of the driver side cam cover. Use tape or zip ties to secure the extension harness to the main harness.





PREMIUM FUEL REQUIRED

CANISTER PURGE VALVE WIRING

1. Locate the Canister Purge Valve electrical connector at the front of the passenger side cylinder head. Remove and discard the 90 degree wire retainer. Use a proper de-pinning tool to remove the connector from the harness.

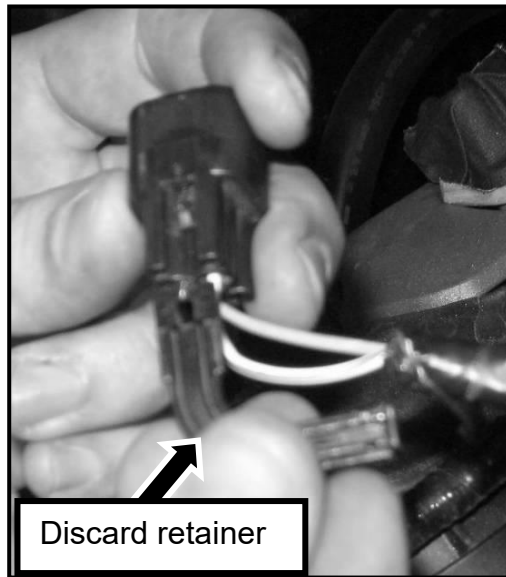
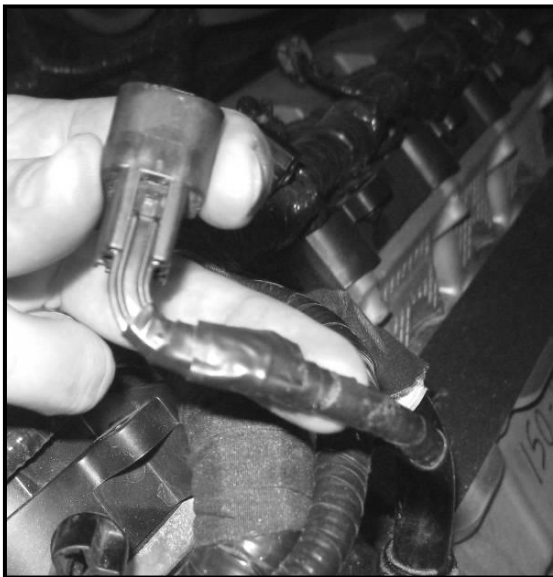



ROUSH[®]
P E R F O R M A N C E

PREMIUM FUEL REQUIRED

2. Depress the locking tab and separate the “empty” female 1 x 2 connector from the Canister Purge Valve Extension harness (13119G866). This connector replaces the connector removed in the previous step. **Carefully pull the white locking tab forward to allow wires to be installed into the connector.** Populate the new connector such that the white with brown wire is in position 1 and the green wire is in position 2. Depress the white locking tab to secure the wires.



3. Connect the Canister Purge Valve Extension harness to the newly installed connector. The wire colors on each side of the connector pair should align. Route the harness along the main wiring harness to the rear of the driver side cam cover. Use tape or zip ties to secure the extension harness to the main harness.





PREMIUM FUEL REQUIRED

INTERCOOLER PUMP WIRING

1. Locate the stud next to the underhood fuse box near the passenger side headlight. Remove the wiring harness from this stud. The harness will be re-attached to this stud in a later step.

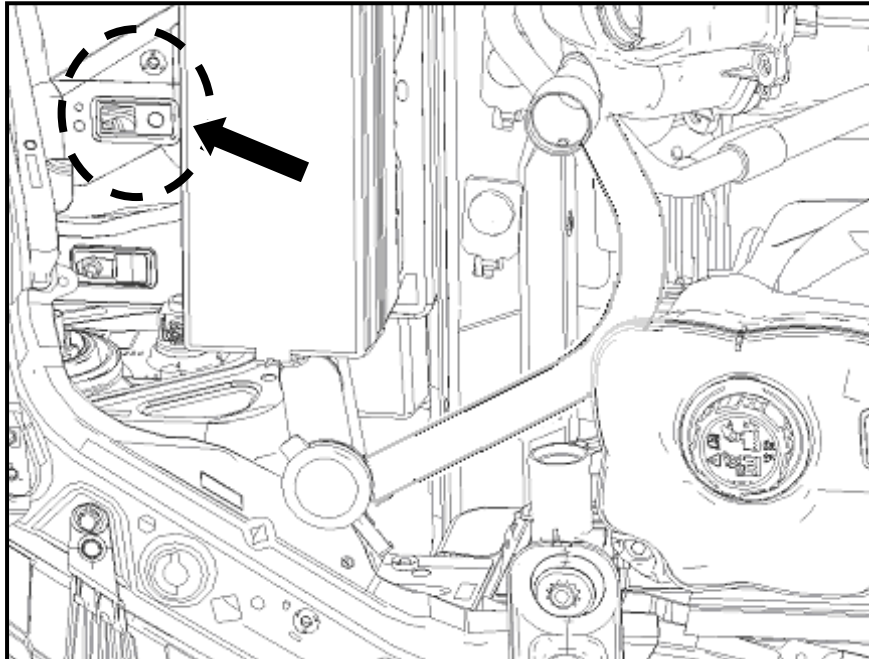

2. Install the relay from the Intercooler Pump Wiring Harness (13118W501) onto the stud. Install the fuse on top of the relay onto the same stud. Use (1) M6 nut (W520412) from the Intercooler Hardware Kit (13116066FRTHKE) to secure the relay and fuse to the stud. Torque the nut to 8-12 Nm. Reinstall the wiring harness from previous step to the stud for proper retention.





PREMIUM FUEL REQUIRED

3. Route the red wire (part of the Intercooler Pump Wiring Harness installed above) to the positive post at the rear of the fuse block. Remove the nut from the positive post and install the red wire eyelet. Reinstall the nut onto post. Torque to 8-12 Nm.

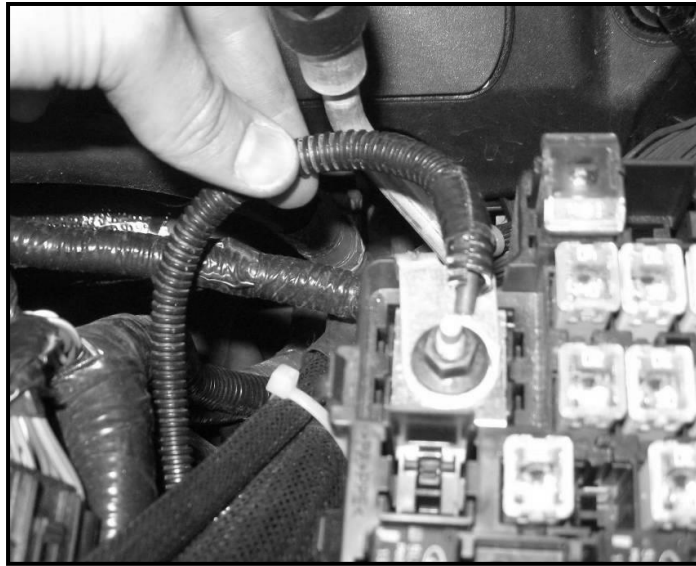

4. Route the other bundle of wires coming from the relay around the front of the fuse box along the factory forward lamp harness. Remove (1) bolt securing the factory ground wires to the chassis behind the headlight. Replace the bolt to secure the factory grounds including the grounding eyelet from with the intercooler pump harness.

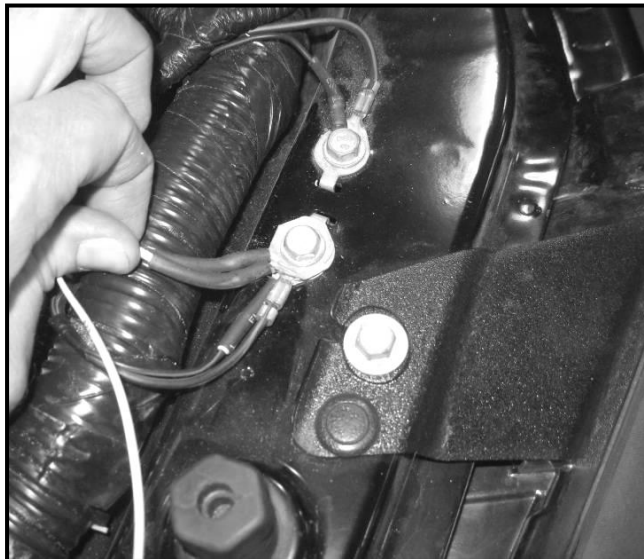

5. Route the single wire with two electrical connectors along the factory engine harness to the rear of the passenger side cylinder head. Connect these two connectors in-line with the passenger side radio capacitor. The single connector will be routed to the intercooler pump in Section D of this manual.



PREMIUM FUEL REQUIRED

AIR CHARGE TEMPERATURE (ACT) WIRING

1. Unplug the 3 PCM connectors by pushing the gray connector lock arms towards the front of the vehicle. You will be working with the bottom 70 pin or "cowl" connector only.
2. a) Remove the pin locking device as shown in figures 2 and 3. Also remove the wire support on the back of the connector (figure 5) by removing the tape and using a small screwdriver to lift the locking tabs.

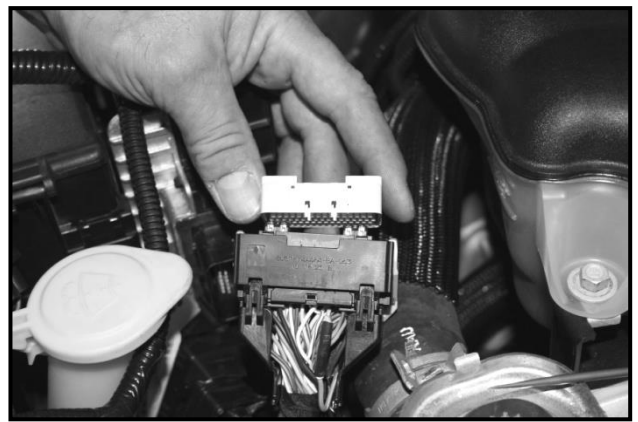

3. The ACT sensor loom (1311-12A690) will have the ACT sensor connector at one end. On the other end will be 2 wires, one with a blunt end and the other with a pin already crimped on. The blunt wire will be spliced into the wire located in pin C-56 of the cowl connector. The wire with the pin will be inserted into location C-36 of the cowl connector. There are small numbers on the back of the connector noting location. Figure 4 below will also help to identify the pin locations.

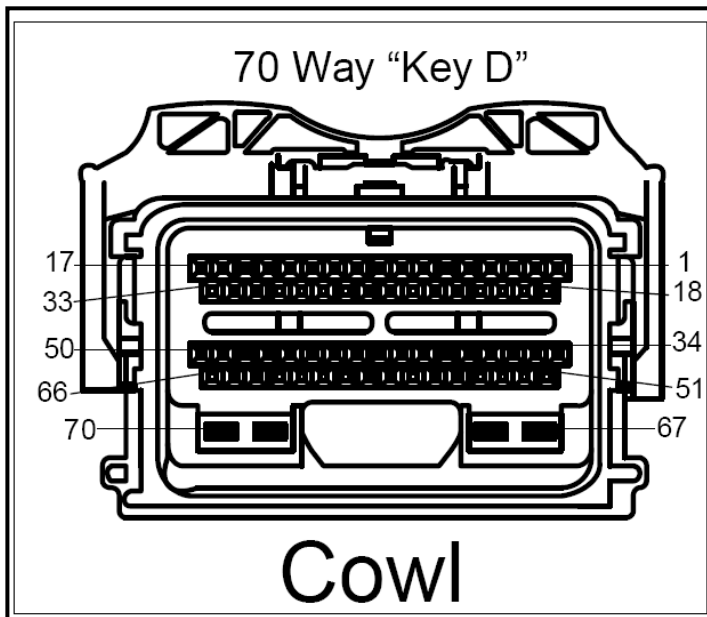

Figure 4: PCM Pin Locations for Cowl Connector – Front View (side that connects to PCM)



PREMIUM FUEL REQUIRED

b) Remove pin C-56 from the connector by **gently** moving the locking tab away from the pin on the front of the connector and pulling the wire out of the back of the connector. Remove the insulation from a 1/2" section of the pin C-56 wire and 1/2" of the end of the blunt wire on the ACT loom. Solder the two wires together and seal them with the supplied shrink wrap. Reinsert the spliced wire into the C-56 location. Note the orientation of the pins on the front of the connector and reinstall the pin in the same way. If the pin is turned it will not lock. The finished/inserted splice is shown in figures 5 and 6 (green wire with black shrink wrap).

c) Insert the ACT loom wire with the pin into the empty C-36 location of the connector. The back of the connector may have a blank cover at the C-36 location. **Carefully** push this blank cover in with a small screw driver or punch to allow you to insert the pin. Note the orientation of the pins on the front of the connector and install the new pin in the same way.

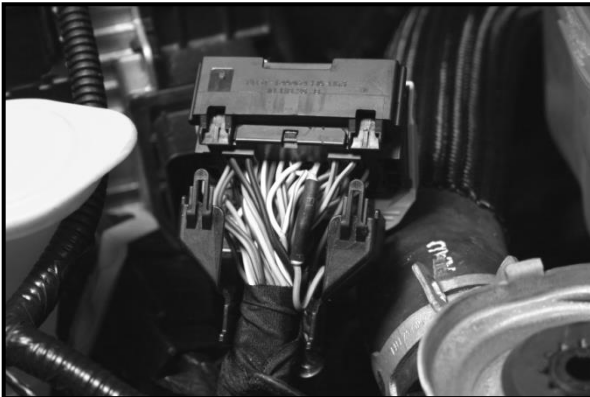

Figure 5



Figure 6

4. a) Reinstall the pin locking device by snapping it into place. Reinstall the wire support on the back of the connector and wrap with tape as before.

b) Reconnect the PCM connectors and route the ACT loom wire along the top of the cylinder head as shown in figure 7.

Figure 7





PREMIUM FUEL REQUIRED

MASS AIR FLOW (MAF) WIRING

1. Locate the MAF wire harness connector and de-pin the factory MAF connector using a proper de-pinning tool. Remove the pin locking device from the front face of the connector and remove the connector from the harness, retain the pins crimped to each wire as shown.

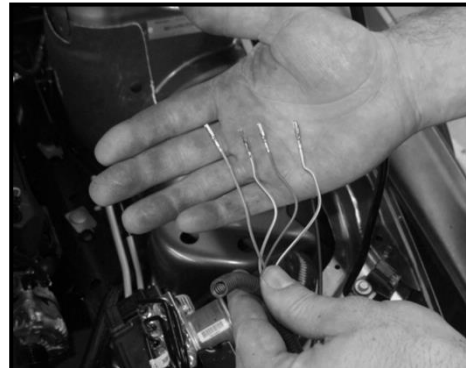
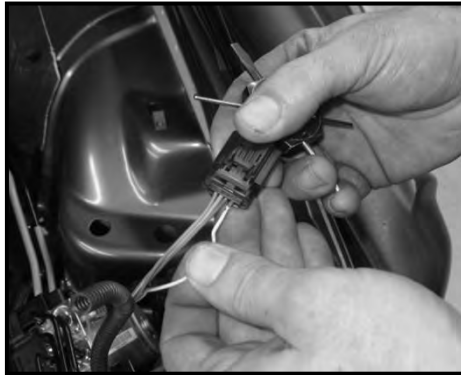

2. Insert the pins from the factory connector into the female connector provided on the end of the MAF Extension Harness (131112B579W). The following color wires go into the following positions on the clip: Violet with Grey – position #2, Grey with Yellow – position #3, Blue with White – position #4, and Yellow with Violet – position #5. NOTE- Positions 1 and 6 are not used.

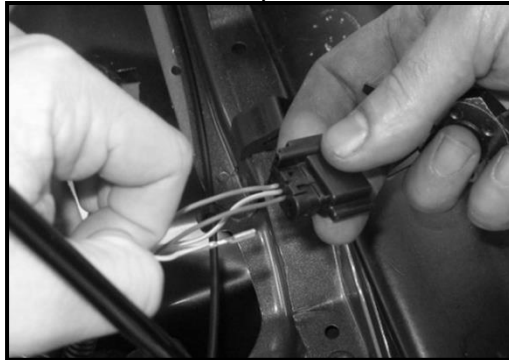

3. Perform a visual inspection of the newly pinned connector to ensure that wire colors match on both sides of the harness. Re-install the pin locking device on the front face of the connector.





ROUSH[®]
P E R F O R M A N C E

PREMIUM FUEL REQUIRED

4. Locate the MAF Extension harness (1311-12B579W). Remove one of the two push pins on the harness and remove the electrical tape. Move the push pin about halfway on connector. Use electrical tape to secure to harness.



5. Connect the new MAF extension harness to the new connector and route the MAF extension harness around the outer perimeter of the lower air box.



PREMIUM FUEL REQUIRED

KNOCK SENSOR ORIENTATION ADJUSTMENT

1. Loosen the two bolts which retain the knock sensors to the engine block and rotate the RH and LH knock sensor toward the RH and LH cylinder heads respectively. In order to do so, first remove the 90 degree plastic wiring retainer clipped to the connector and taped to the wiring convolute. Torque the knock sensor bolts to 20-30Nm.

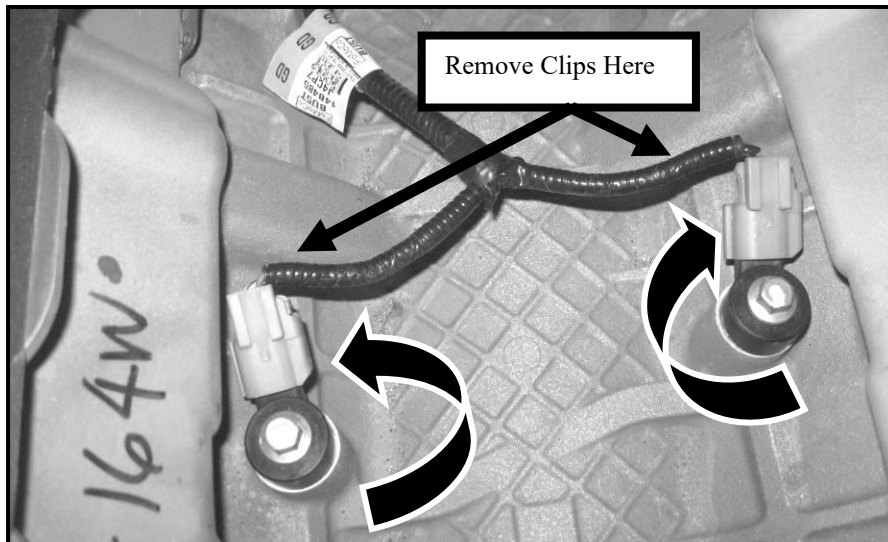

CHANGING THE FACTORY SPARK PLUGS

1. Disconnect the electrical connectors for each ignition coil (8 places) and remove the fastener holding the coil on plug in place. Remove the ignition coil on plug. A slight twisting motion will break the seal and ease removal. Remove the factory spark plugs (8 places) and set aside. These will not be re-used.
2. Install the eight (8) provided spark plugs (CYFS12YP) which are gapped to 0.9 mm. Torque to 14 Nm (124 lb-in). Install the ignition coil on plugs. Apply a small amount of dielectric grease to the inside of the coil on plug boots before attaching to the spark plugs. Torque the bolts to 6 Nm (53 lb-in). Re-install the coil on plug covers.
3. Locate two (2) spark plug warning labels (PT00045644, found in 1121-HWKF). Place 1 label on cylinder 1 and cylinder 5 coils (front coil of RH and LH cam cover).





PREMIUM FUEL REQUIRED

SECTION C – SUBASSEMBLY

INTERCOOLER LOW TEMPERATURE RADIATOR (LTR)

1. Insert (1) Rubber Grommet (R07060107) found in Hardware Kit E (13116066FRTHKE) into each mounting tab on the Low Temp Radiator LTR (13108K229).

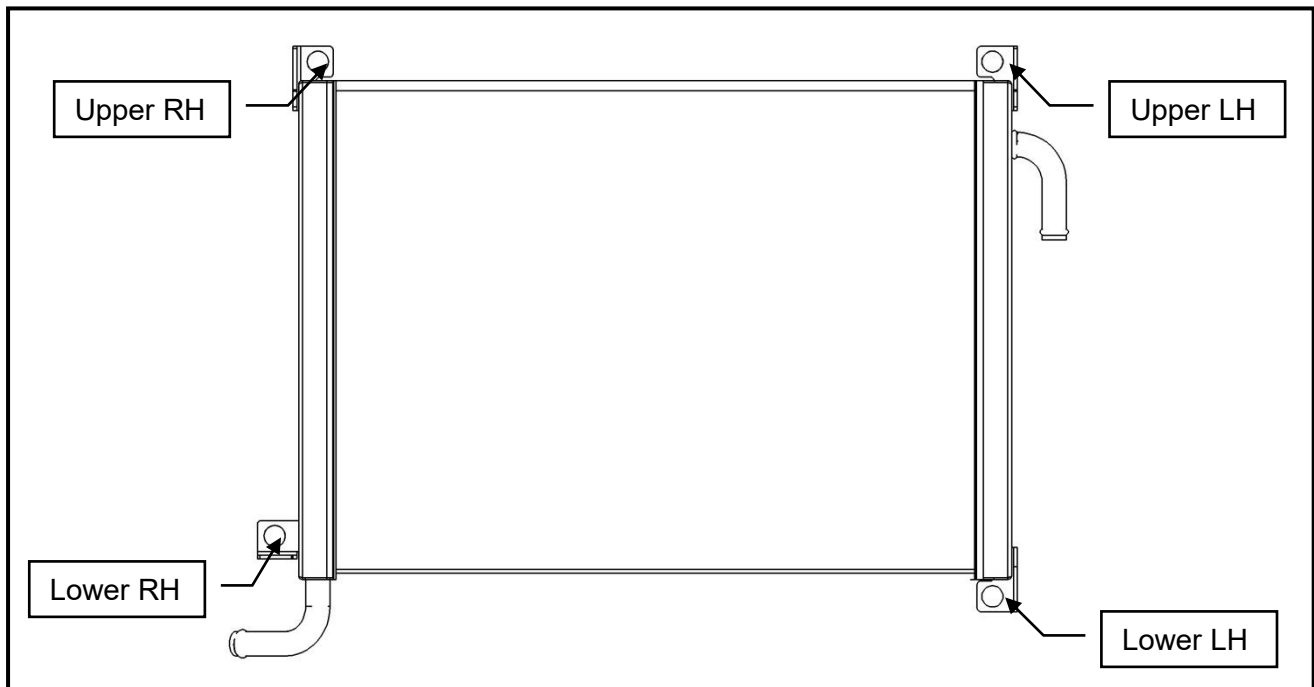

2. Push (1) Sleeve (R07060108) found in Hardware Kit E (13116066FRTHKE) into each of the rubber grommets previously installed.



PREMIUM FUEL REQUIRED

3. Mount the Upper LH LTR Bracket (13108K242) to the upper LH corner of the LTR using (1) M8 x 1.25 x 25mm bolt (W500224). These can be found in Hardware Kit E (13116066FRTHKE). Align the edges of the bracket such that they are flush with the mounting tab on the LTR. Torque bolt to 20-30 Nm.

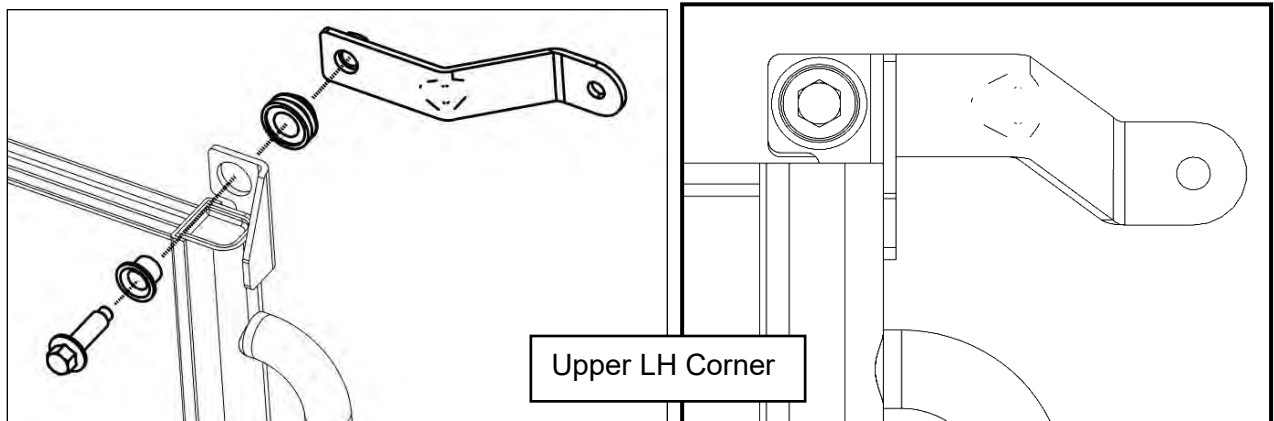

4. Repeat step 3 for each of the remaining LTR Brackets. 13108K243 will go to the upper RH corner, 13108K244 to the lower LH corner and 13108K245 to the lower RH corner of the LTR. These can be found in Hardware Kit E (13116066FRTHKE).

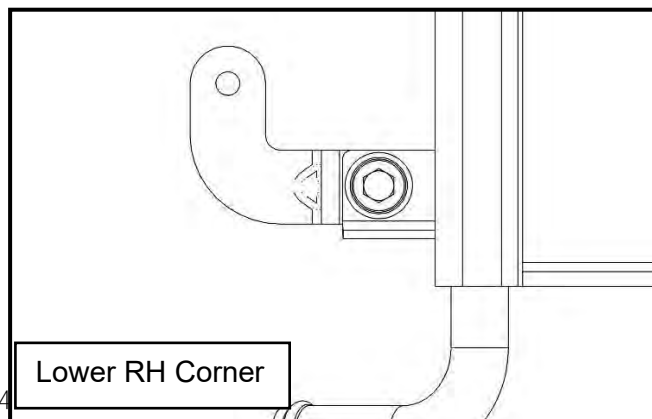
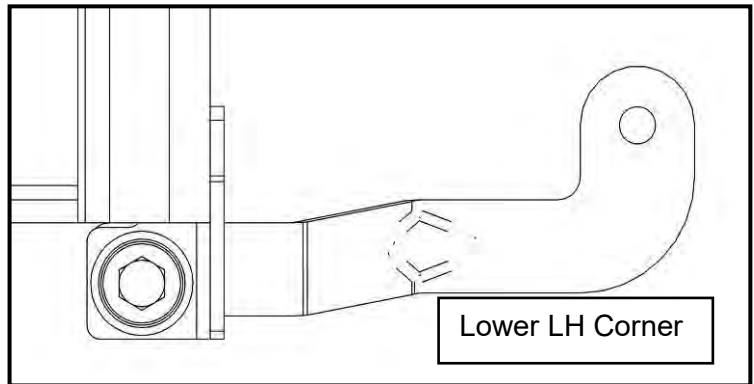
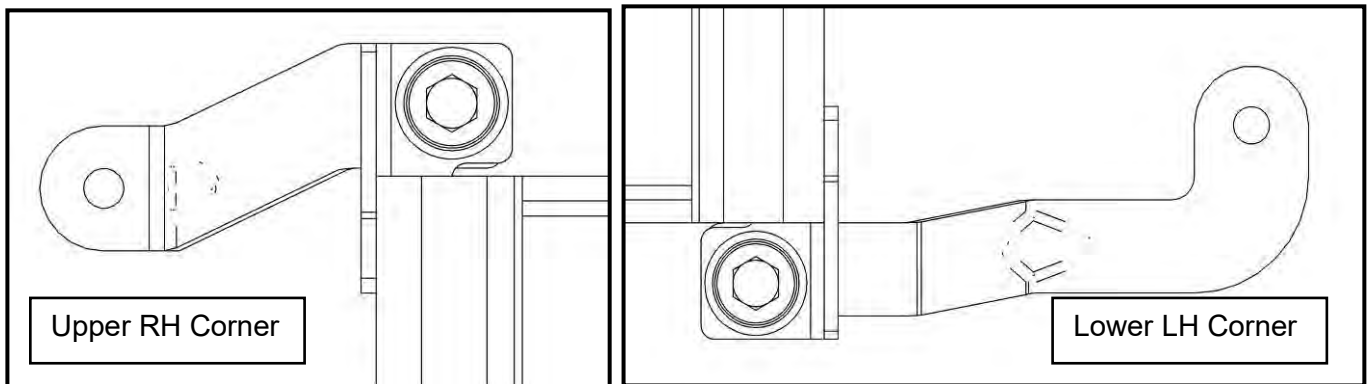



ROUSH[®]
P E R F O R M A N C E

PREMIUM FUEL REQUIRED

5. Install the Intercooler Pump to LTR NVH Isolator (13108Y419) on the front face of the LTR. The pad should be stuck to the LTR so that it is 170mm from the top and 140mm from the right side.

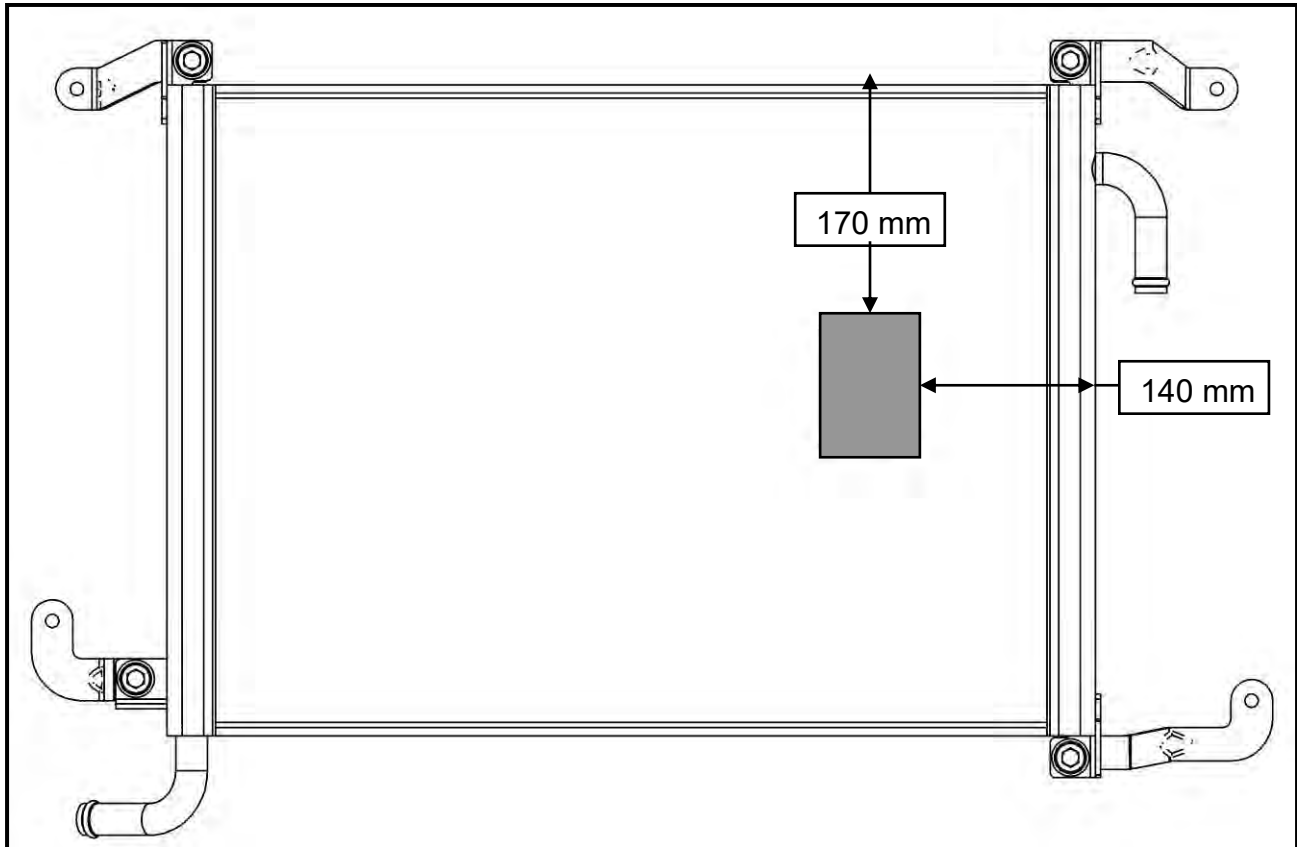



PREMIUM FUEL REQUIRED

INTAKE MANIFOLD BUILD UP

1. Remove Fuel Charging Assembly (13119H487) from the packaging.
2. Attach the rubber hose from the PCV Purge Hose (13116K817) to the bubbler fitting (3/8" barb) on the bottom of the fuel charging assembly and secure it with the supplied clamp.

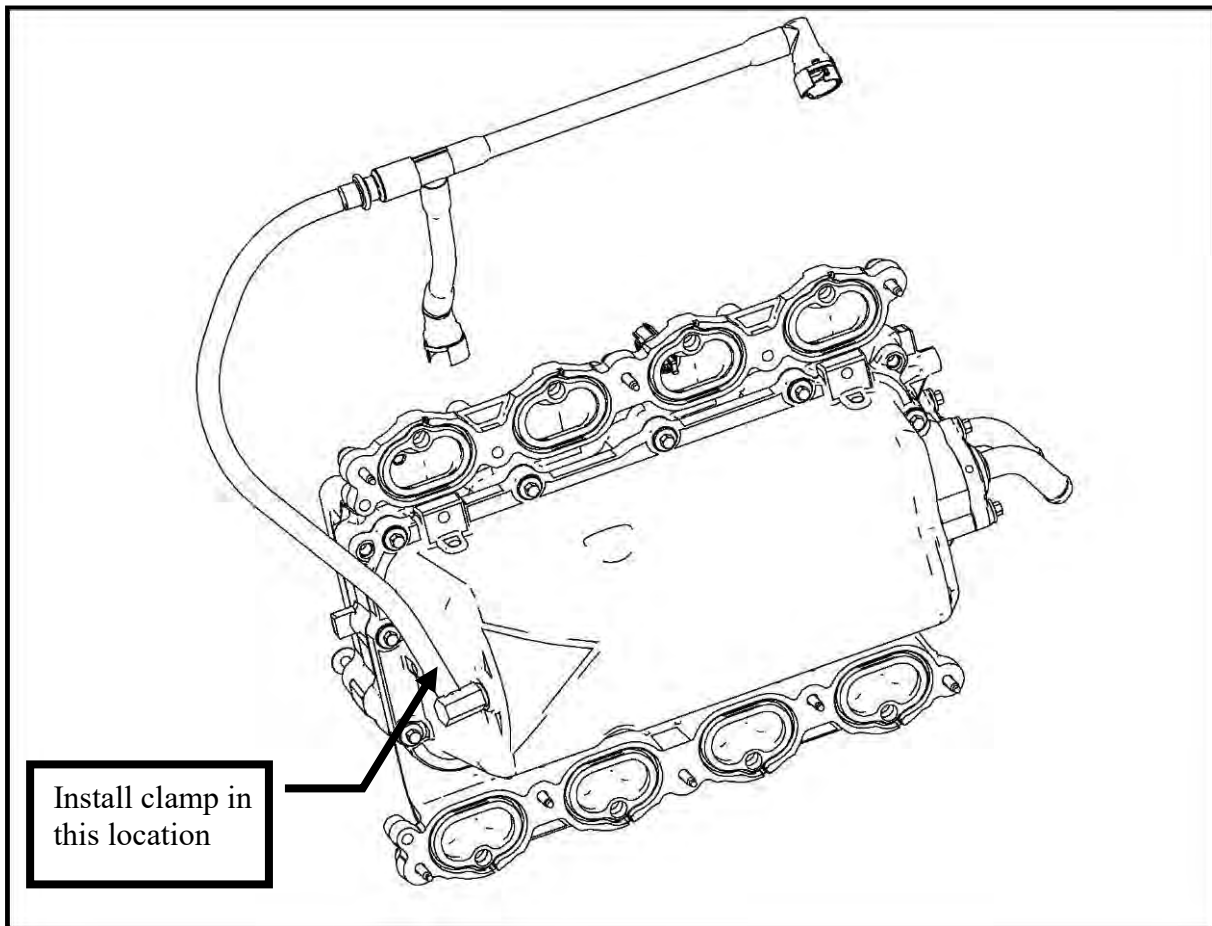



PREMIUM FUEL REQUIRED

THROTTLE BODY SPACER ASSEMBLY

1. Remove the Evaporative Emission Canister Purge Valve from the stock intake manifold.

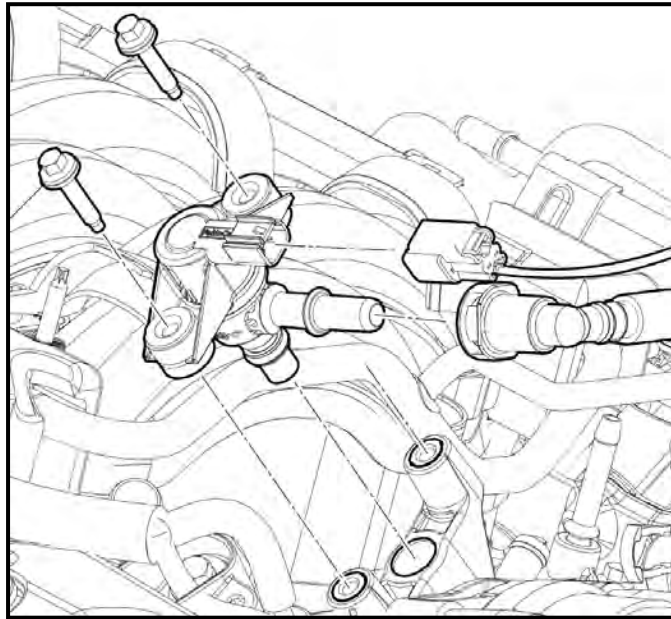

2. Install the valve into the new Throttle Body Spacer using (2) M6 x 1.0 x 35.5 mm bolts (N808429) found in Hardware Kit B (1311-TVSHKB). Torque bolts to 8-12 Nm.

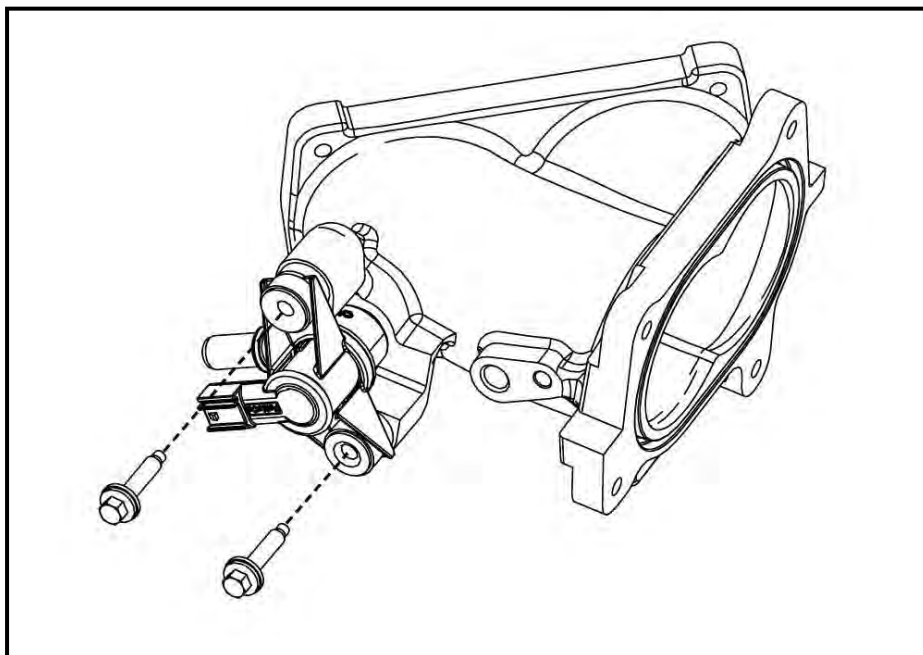



PREMIUM FUEL REQUIRED

3. Connect the supercharger boost bypass actuator hose (R18140001) to the throttle spacer.

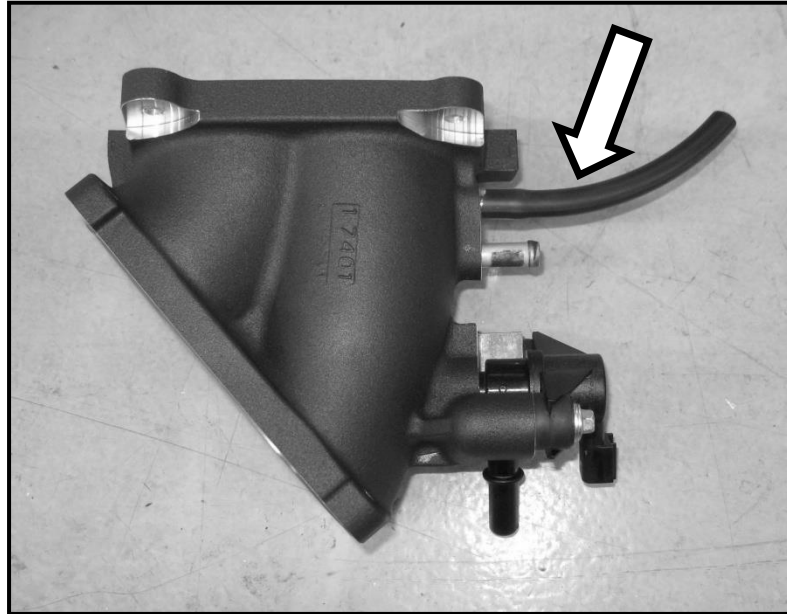

- 4A. **(MANUAL TRANS. ONLY)** Connect the marked end of the modified brake booster hose to the throttle spacer.

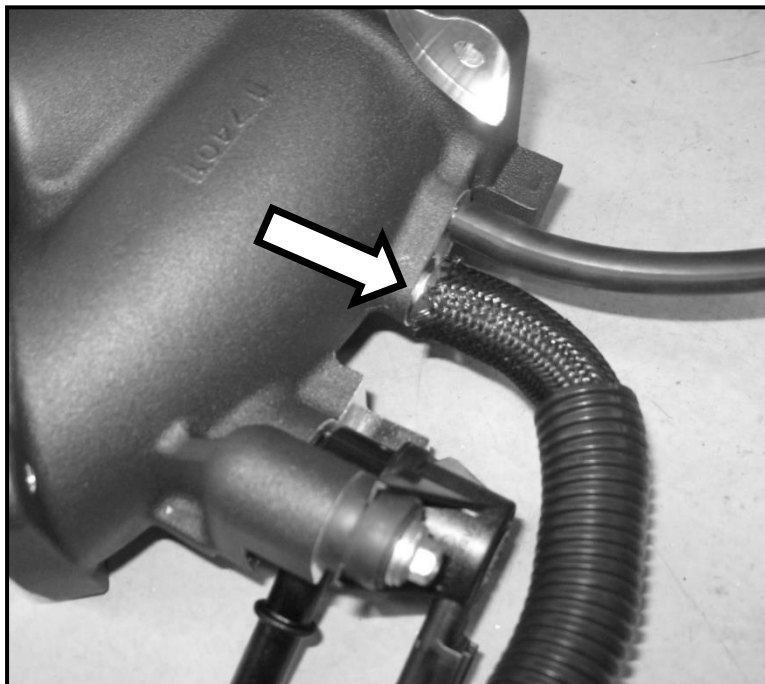



ROUSH[®]
P E R F O R M A N C E

PREMIUM FUEL REQUIRED

4B. **(AUTO TRANS ONLY)** Using the finished brake vacuum aspirator assembly from Section C – Subassembly, install the end of hose 2A to the fitting on the throttle body spacer. Secure the hose with Clamp 4.





PREMIUM FUEL REQUIRED

FUEL RAIL ASSEMBLY

1. Carefully install the eight (8) new Anti-Rotation Fuel Injector Clips (1311-9C995) onto the new Fuel Injectors (M-9593-LU47RSH).

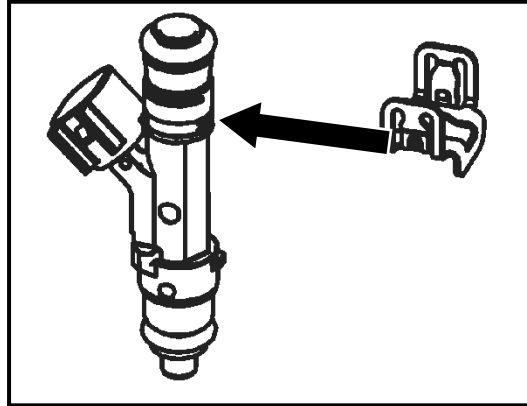

2. Apply assembly lube to the injector O-rings and install the injectors into the new Fuel Rail (13119F792). **NOTE:** Verify that the anti-rotation clips are properly aligned and fully engaged into the fuel rail injector cups.

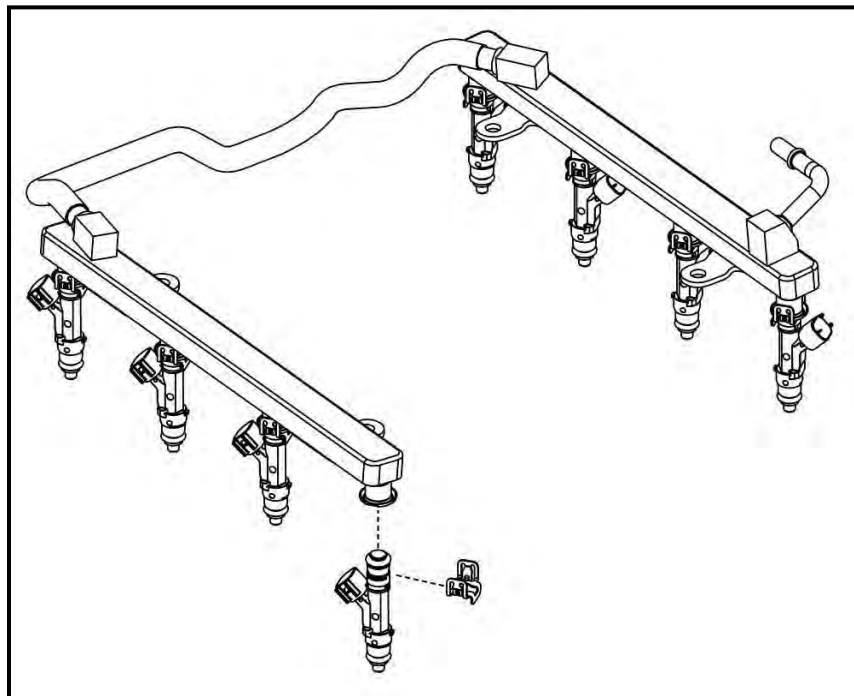



PREMIUM FUEL REQUIRED

AIRBOX ASSEMBLY

1. Install the twelve inch length of edge seal (39-211) around the circular opening edge of the air box where the MAF Tube will be located. Position the seal so the ends start and stop on the bottom side.

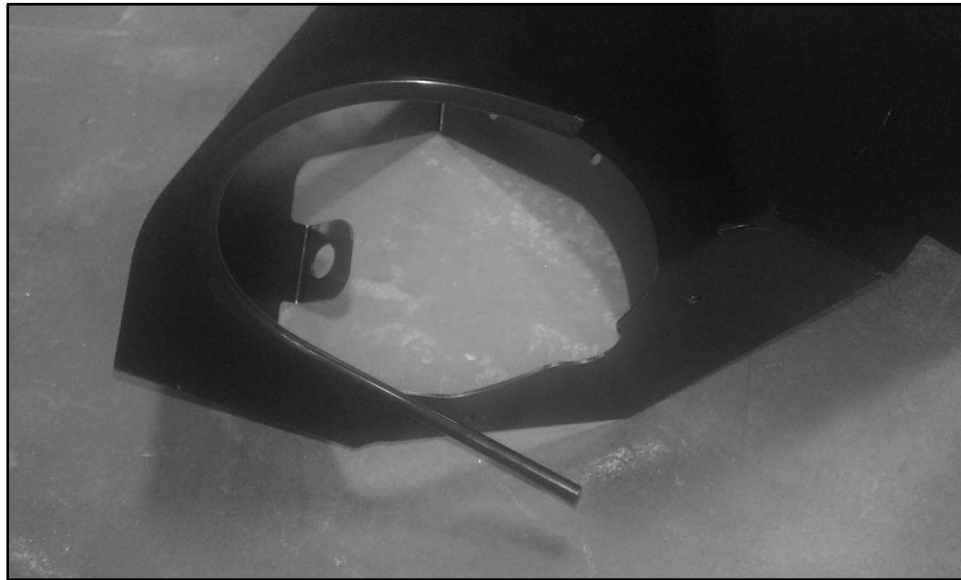

2. Place the MAF tube (R07060101-13) through the opening of the airbox (1313-9643) from the inside. Install the mounting bracket (R07130010-13) onto the MAF Tube using one M6x14 bolt (N605771). Align the point on the bracket with the mark on the tube and torque to 10Nm.

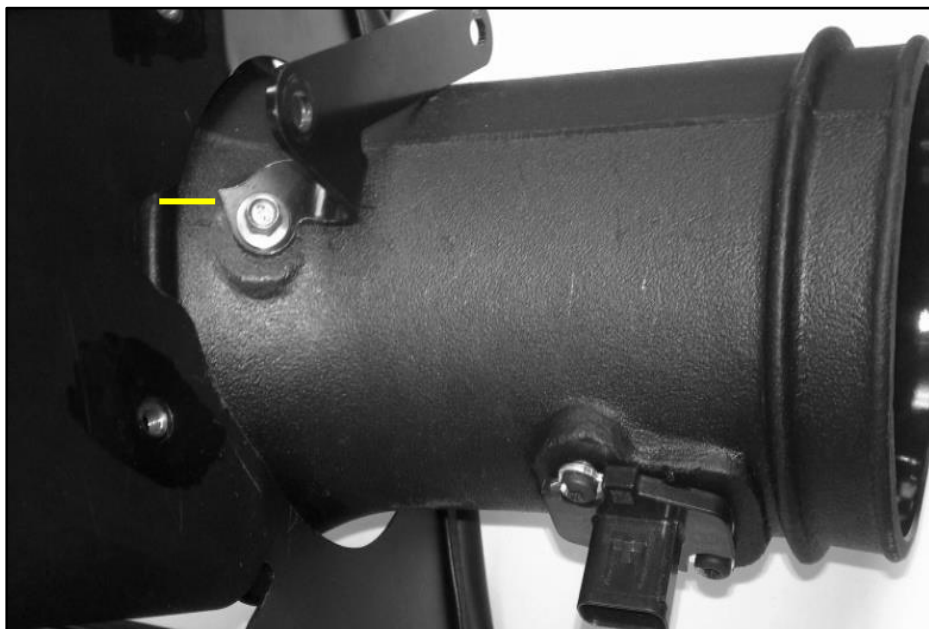



PREMIUM FUEL REQUIRED

3. With the two remaining M6 x 14 fasteners (N605771) secure the bracket to the back of the box and torque to 10 Nm.



4. Install the stock MAF sensor into the MAF Tube (R07060101) using the MAF Bolts (M4 X 0.7 X 10) and tighten with a T-20 Torx bit. Torque the screws to 1.8 – 2.2 Nm. Be careful not to over tighten these screws. Wiggle the MAF sensor to ensure that it is properly fastened.





PREMIUM FUEL REQUIRED

5. Install the retaining grommet from the factory airbox into the mounting tab on the new Airbox Assembly (1313-9643). Tip – Remove the center bushing while installing the rubber grommet through the hole in the tab. Re-install the center bushing once the grommet is fully seated.

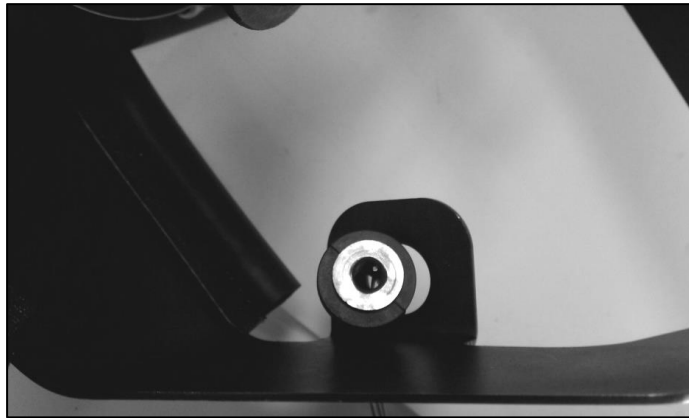

6. Remove the rubber mounting isolators from the bottom of the factory airbox and install them onto the mounts on the bottom of the new airbox in the same orientation.

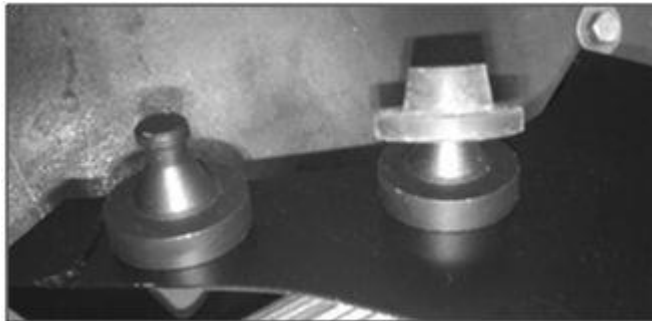

7. Install the Filter (997-495) onto the MAF Tube. Torque clamp to 3 – 5 Nm.

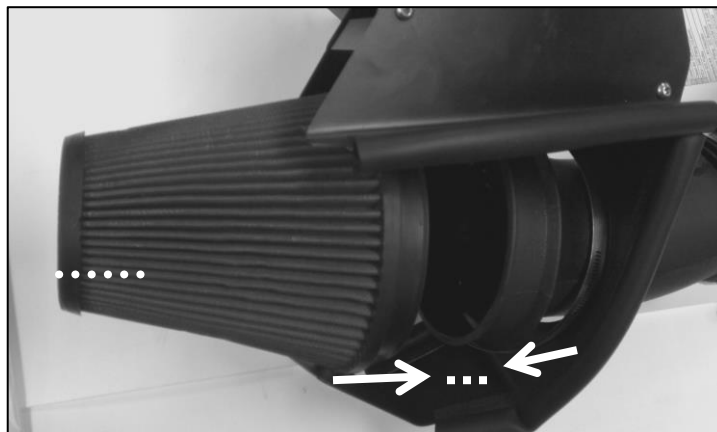



ROUSH[®]
P E R F O R M A N C E

PREMIUM FUEL REQUIRED

8. Install the Clean Air Tube (1313-9B659-AA) onto the MAF Tube. (NOTE: MAF and PCV port are located on the same side).





PREMIUM FUEL REQUIRED

SECTION D – INSTALLATION

The following section will guide you through the final installation of the kit into the vehicle. If you need to stop during any part of the installation, make sure you cover any open ports in the cylinder heads or intake manifold to prevent foreign material from contaminating your engine.

INTERCOOLER RESERVOIR MOUNTING

1. Install the Intercooler Degas Bottle (13108D080) with Degas Bottle Cap (9C3Z-8101-B) onto the fan shroud using (1) M6 x 1.0 x 22 mm bolt (R18020057) from Hardware Kit E. Use the bottle as a template to mark the second mounting hole with a paint pen. Remove the bottle and drill a 5/16" hole through the fan shroud.

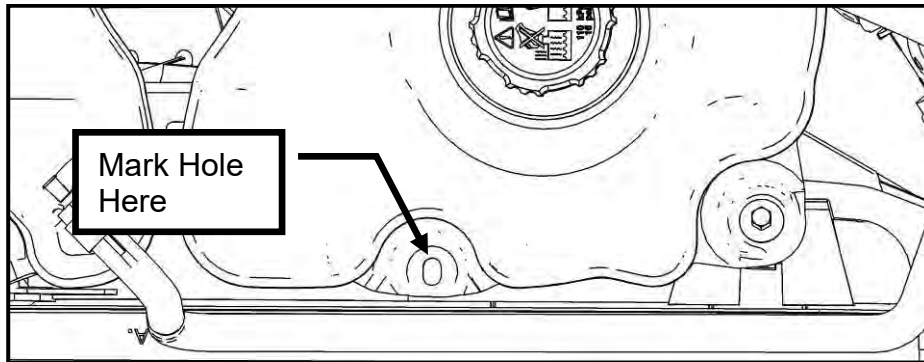

2. Install (1) M6 J-Clip (N623332) from Hardware Kit E onto the fan shroud. Reinstall the fan shroud and bolts and torque to 8-12 Nm. Reinstall the intercooler degas bottle using (2) M6 x 1.0 x 22 mm bolts (R18020057) and torque to 8-12 Nm.

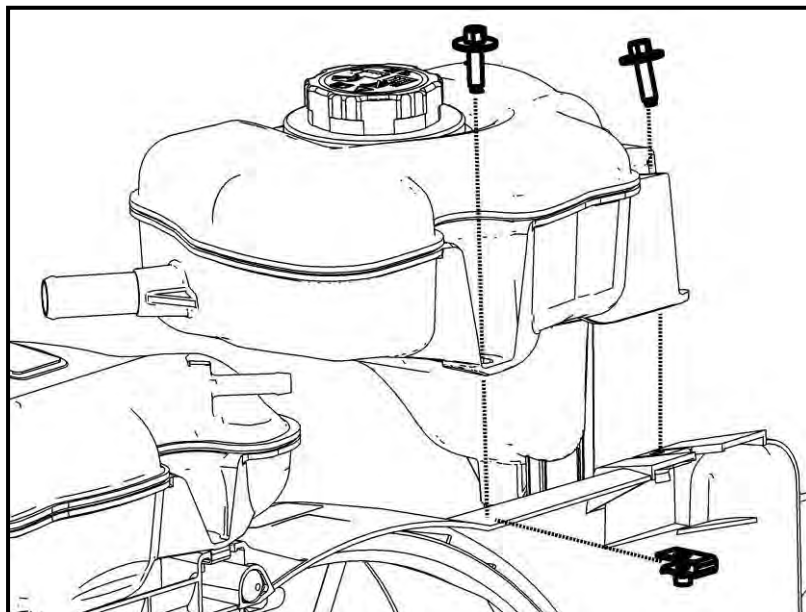



PREMIUM FUEL REQUIRED

The following steps are for vehicles equipped with Automatic Transmissions; if your vehicle is equipped with a Manual Transmission please skip to Intercooler Radiator Assembly Mounting.

AUTOMATIC TRANSMISSION OIL COOLER HOSE

1. Wrap the transmission hose (1312-7R081) provided in the parts kit (GY2021-1/2) with $\frac{3}{4}$ " split convolute provided in the parts kit (1312-TRANSCONV). Finish the ends with electrical tape. Attach one end to the oil cooler outlet and route as shown. Reuse existing clamp.

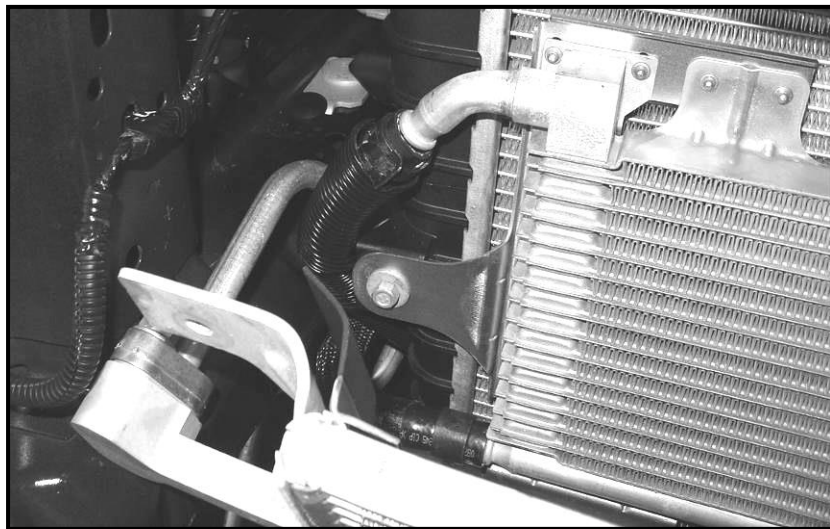

2. Attach the opposite end of the transmission oil cooler hose to the transmission line straight connector as shown. Secure the hose to the connector using the $\frac{3}{4}$ " worm clamp (5407K58) provided in the parts kit. The transmission oil cooler hose is shown without the $\frac{3}{4}$ " convolute for clarity.





PREMIUM FUEL REQUIRED

3. Wrap both transmission oil cooler hoses coming from the transmission with 12 inches of $\frac{3}{4}$ " split convolute at the FEAD bracket as shown. Finish the ends with electrical tape.

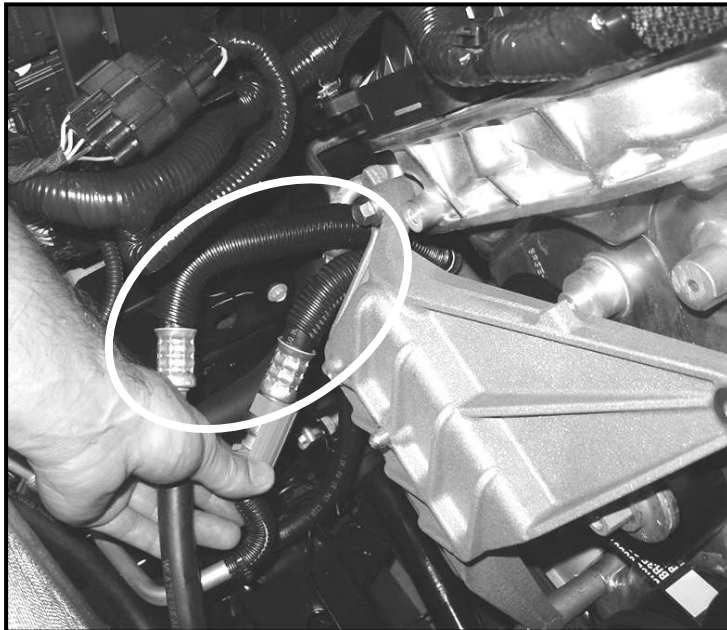

4. Secure the two transmission oil cooler lines to each other and the AC line at the FEAD bracket in two places using the zip ties (KTI—78070) supplied in the Hardware Kit G. Inspect the hose routings to ensure there are no pinched hoses and the convolute is positioned to prevent hose abrasion from other components.

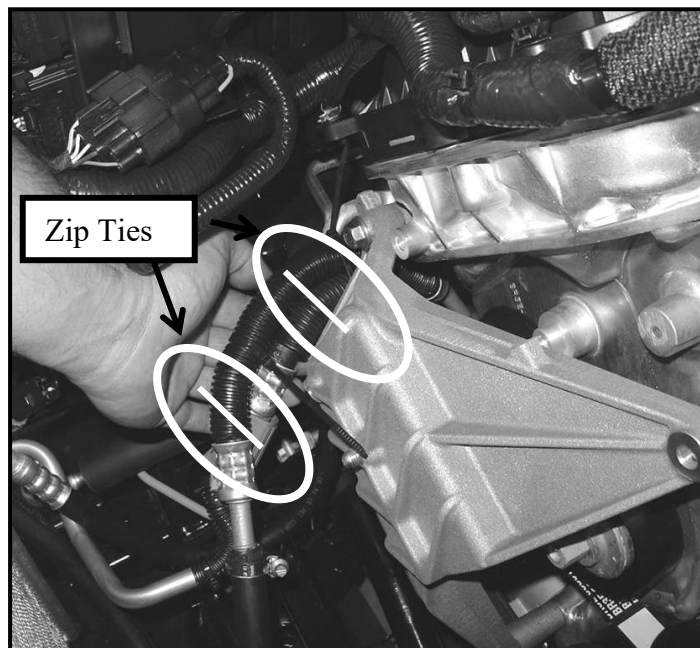



ROUSH[®]
P E R F O R M A N C E

PREMIUM FUEL REQUIRED

5. Wrap the other transmission oil cooler line with 12 inches of $\frac{3}{4}$ " split convolute as shown. Finish the ends with electrical tape.





PREMIUM FUEL REQUIRED

INTERCOOLER RADIATOR ASSEMBLY MOUNTING

1. Remove the stock radiator side shields (See Appendix A). The push pins will be reused.
2. Remove the (2) upper bolts and (2) lower nuts used to secure the air conditioning condenser core to the vehicle. The nuts will be reused.
3. Install the new LTR assembly into the vehicle using (2) M6 x 1.0 x 22 mm bolts (R18020057) found in Hardware Kit E (13116066FRTHKE) at the top, into the radiator and the two nuts that were removed in the previous step at the bottom. Torque the two bolts and two nuts to 8-12 Nm.

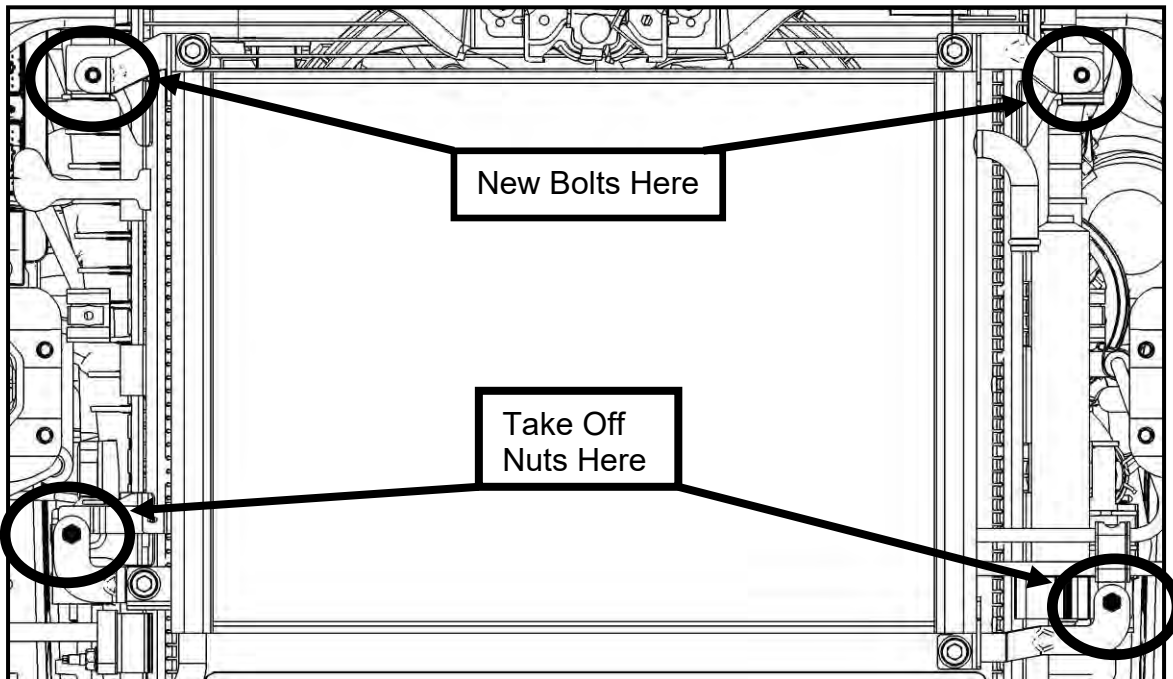



PREMIUM FUEL REQUIRED

ELECTRIC WATER PUMP, MOUNTING BRACKET AND HOSES

1. Install the Intercooler Pump Inlet Hose (13108D029) from the degas bottle outlet port to the front of the LTR by routing the hose around the lower radiator hose "T" joint and along the frame rail. Secure the hose to the bottom of the degas bottle using (1) $\frac{3}{4}$ " constant tension clamp (CT19x12-BO). Orient the clamps so the "I" on the hose is in the center of the clamp tangs.

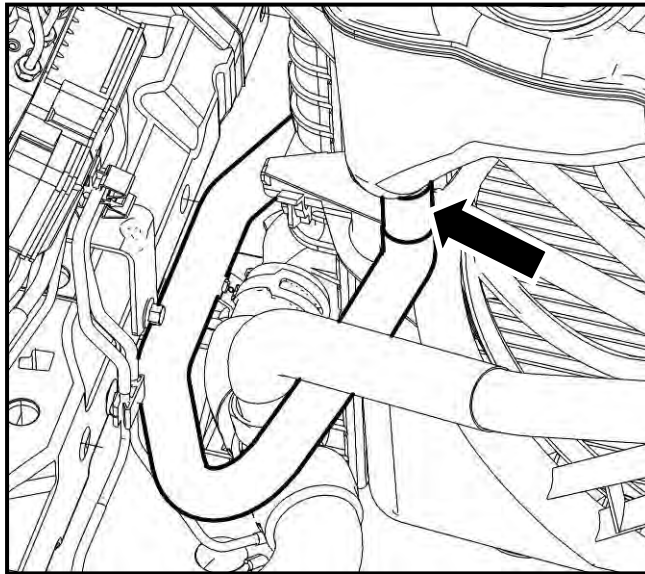

2. Install the modified LH side radiator side shield (See Appendix A) and route the Intercooler Pump Inlet Hose (installed in the previous step) through the new hole in the shield and secure the shield to the chassis using the take off push pins.

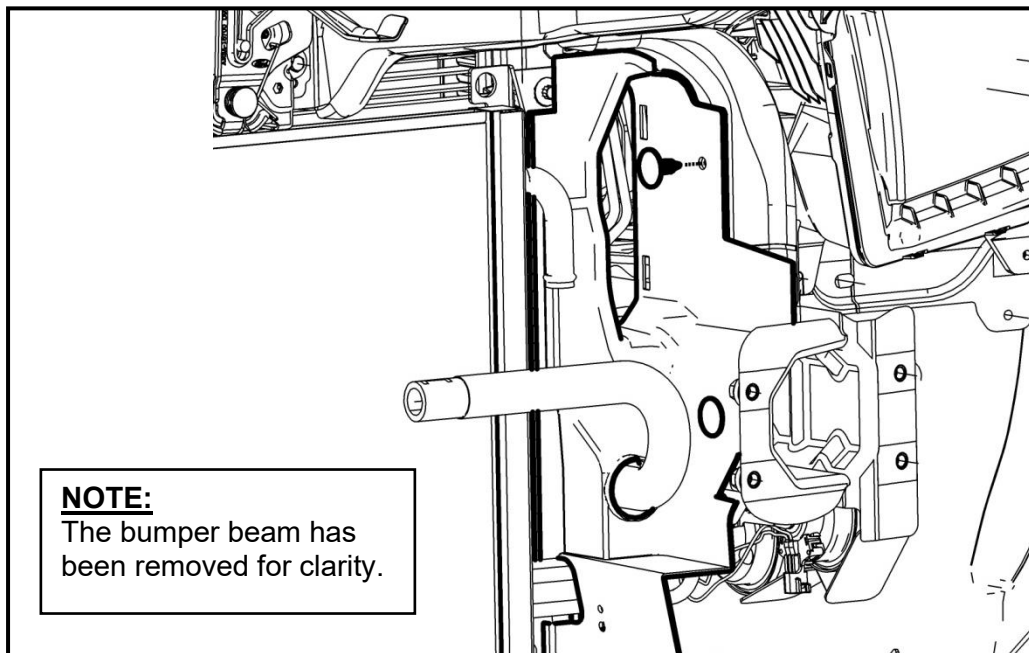



PREMIUM FUEL REQUIRED

3. Install the modified RH side radiator side shield (See Appendix A). Secure the shield to the chassis using the take off push pins.

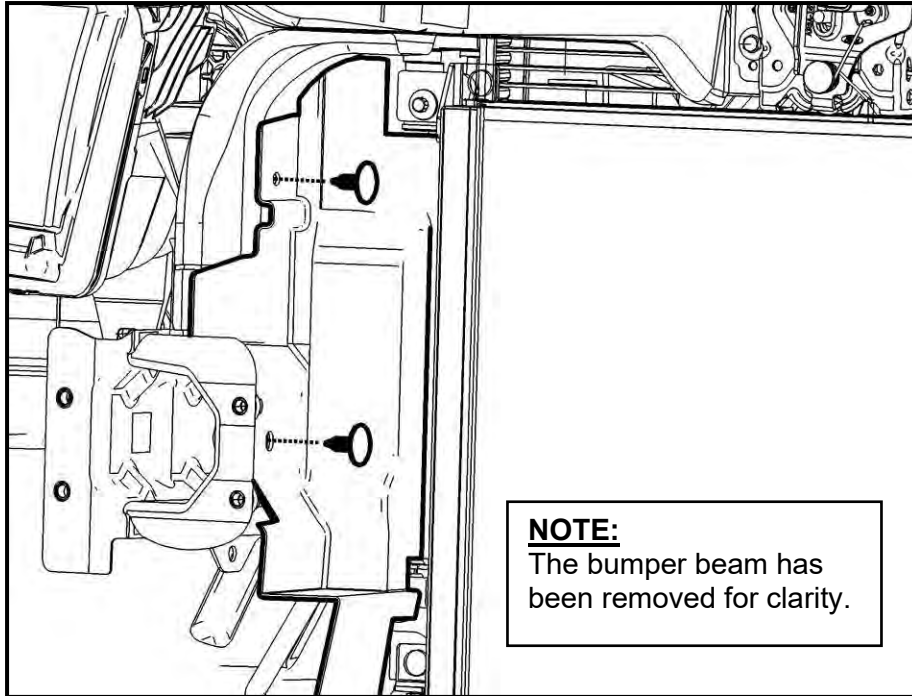

4. Remove the (2) upper, inner front bumper beam bolts.
5. Install the (2) Long Bumper Bolts (R18020007) from Hardware Kit E in place of the (2) which were just removed and torque to 20-30 Nm. Install the Intercooler Pump Mounting Bracket (1313-8C419) behind the bumper onto the long bumper bolts using (4) M8 nuts (W520413) from Hardware Kit E (13116066FRTHKE). Torque these nuts to 20-30 Nm.

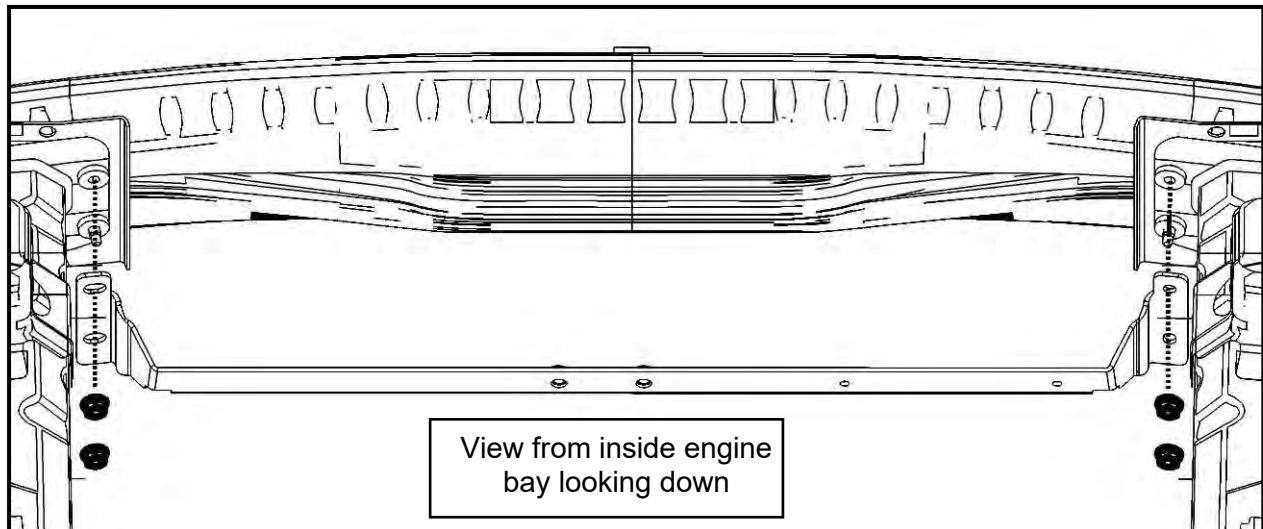



PREMIUM FUEL REQUIRED

6. Install the Intercooler Pump to Bumper Beam NVH Isolator (13108Z419) found in Hardware Kit E, on the rear of the bumper beam such that the edge of the pad is 220mm from the driver side bumper beam mounting plate and 60mm from the front edge.

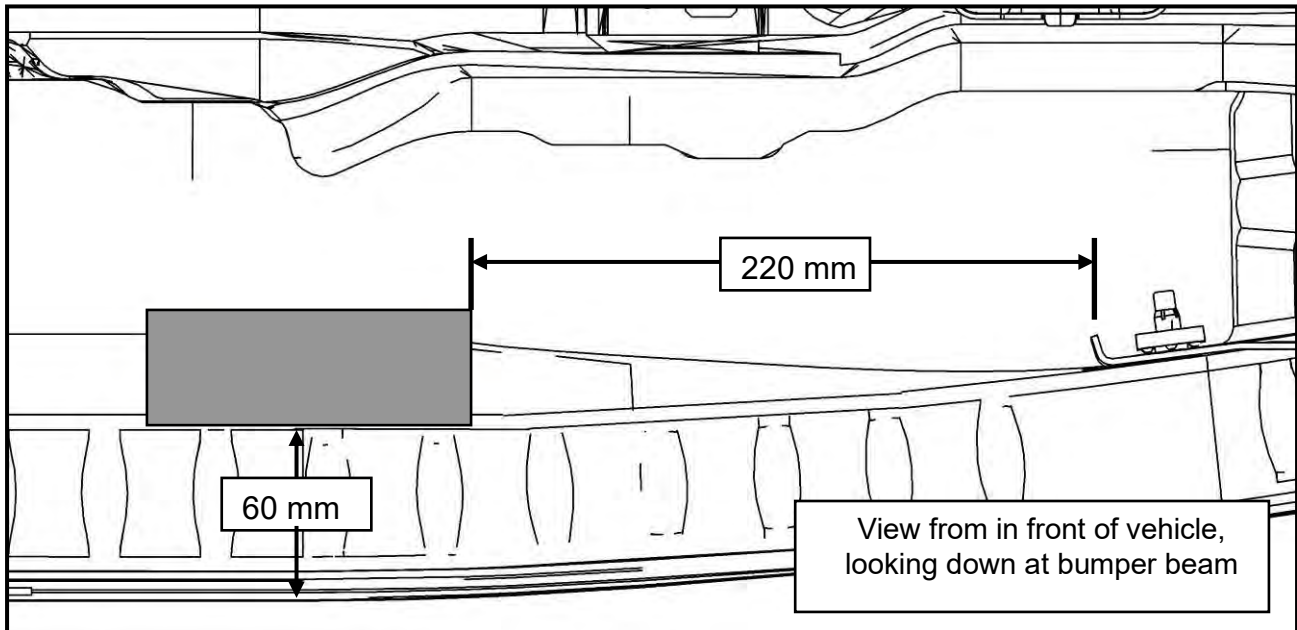

7. Connect the Intercooler Pump to LTR hose (13108K236) to the Intercooler Pump and Bracket assembly (392022009 or FS00057975). If kit includes Pump PN: FS00057975, use P CLIP (8863T95), and M8 Bolt (W500224-S437) to install on bracket. Orient the hose so the "I" is aligned with the arrow on the pump outlet port. Secure the hose to the pump using (1) $\frac{3}{4}$ " constant tension clamp (CT19x12-BO). Orient the clamp so the "I" on the hose is in the center of the clamp tangs.

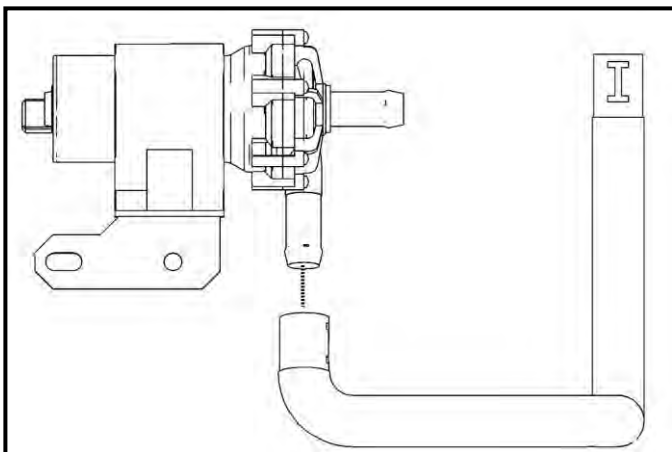

FS00057975-AA



ROUSH
P E R F O R M A N C E

PREMIUM FUEL REQUIRED

8. Secure the Intercooler Pump and hose to the Intercooler Pump Mounting Bracket using (2) M8 x 1.25 x 25 mm bolts (W500224) from Hardware Kit E so the outlet is facing away from the two holes that are in the bracket. Torque bolts to 20-30 Nm. **(SKIP THIS STEP IF PUMP INSTALLED IN STEP 7 WITH P-CLIP)**

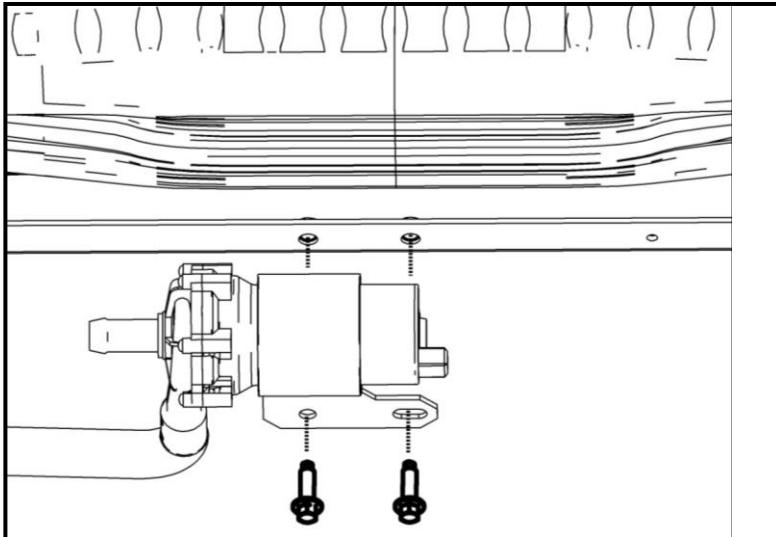

PT00045463-AA

9. Connect the Intercooler Pump to LTR hose to LTR inlet port using (1) $\frac{3}{4}$ " constant tension clamp. Orient the clamp so the "I" on the hose is in the center of the clamp tangs.

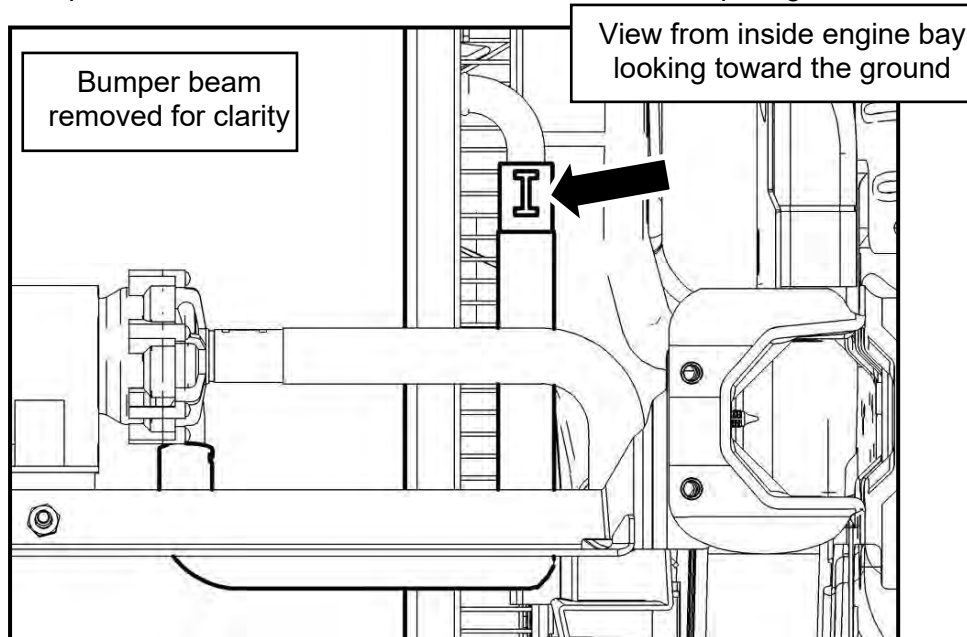

10. Connect the Intercooler Pump Inlet Hose to the inlet port on the intercooler pump. Secure the hose to the pump using (1) $\frac{3}{4}$ " constant tension clamp. Orient the clamp so the "I" on the hose is in the center of the clamp tangs.



PREMIUM FUEL REQUIRED

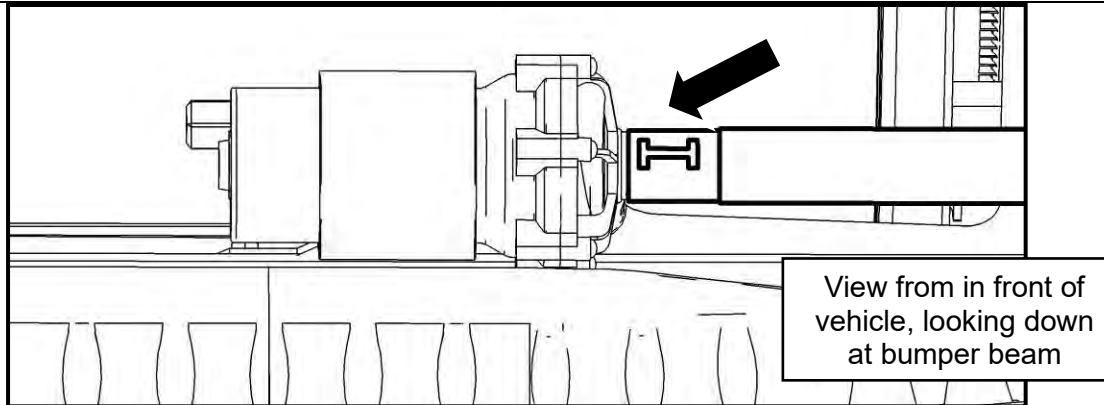

11. Route the remainder of the Intercooler Pump Wiring Harness next to the headlight and radiator and through the hole in the RH Radiator Side Shield. Connect the wiring harness to the pump and secure the harness to the bracket by pushing the push pins on the harness into the holes in the mounting bracket. If Intercooler pump PN: FS00057975 is in your kit, install jumper harness PN: PT00045528 inline between wiring harness and pump.

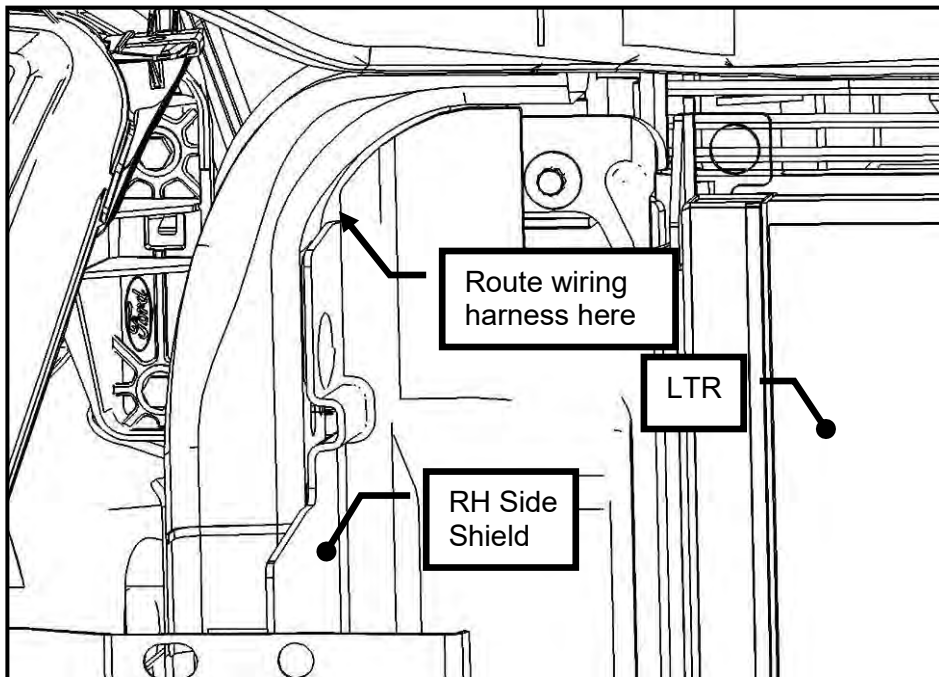

PT00045528-AA

12. Reinstall the impact absorber onto the front bumper beam using the take out pushpins.

Note: Route all intercooler hoses very carefully. It is critical for intercooler performance that these hoses are not kinked once installed into the vehicle.



ROUSH
P E R F O R M A N C E

PREMIUM FUEL REQUIRED

INDUCTION RESONANCE TUBE DELETE GROMMET

1. Install the Induction Resonance Tube Delete Grommet (W651016) in the hole that was exposed when the boom tube was removed.

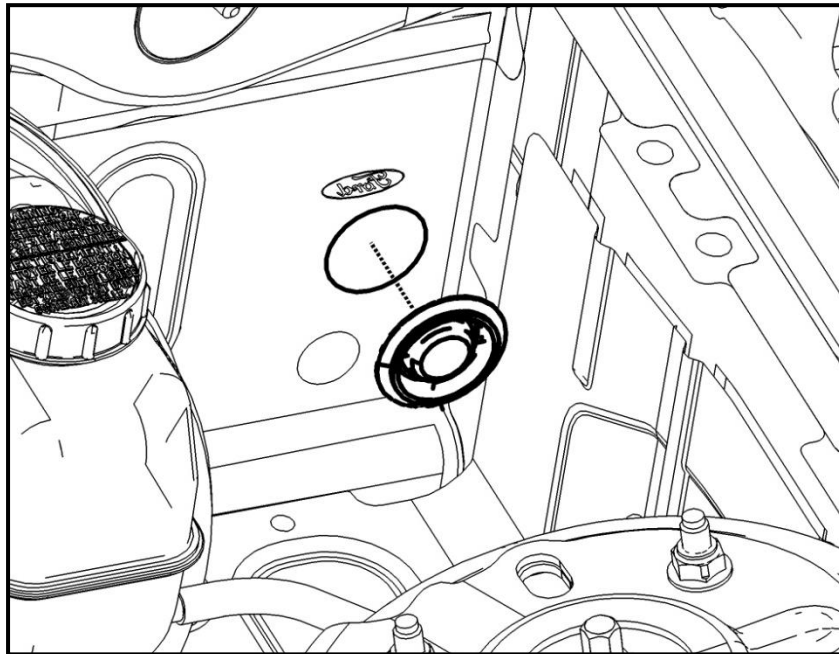

NOTE: If the ROUSH boost gauge kit is going to be installed onto the vehicle, the above grommet can be left out as the boost gauge kit has a pre-installed grommet on the vacuum line that will go in this location.



PREMIUM FUEL REQUIRED

INTAKE MANIFOLD AND SUPERCHARGER INSTALLATION

1. Remove the tape from the cylinder heads and clean the cylinder head to intake manifold mating surfaces.
2. Install the intake manifold using six (6) M6 x 1.0 x 40 mm bolts (R18020004) found in Hardware Kit B (1311-TVSHKB). Install these fasteners in the positions shown and tighten the sequence in two stages. Stage 1; torque bolts to 8-12 Nm. Stage 2; tighten bolts an additional 45 degrees. Reinstall the engine wiring harness retention clips at the rear of the intake manifold.

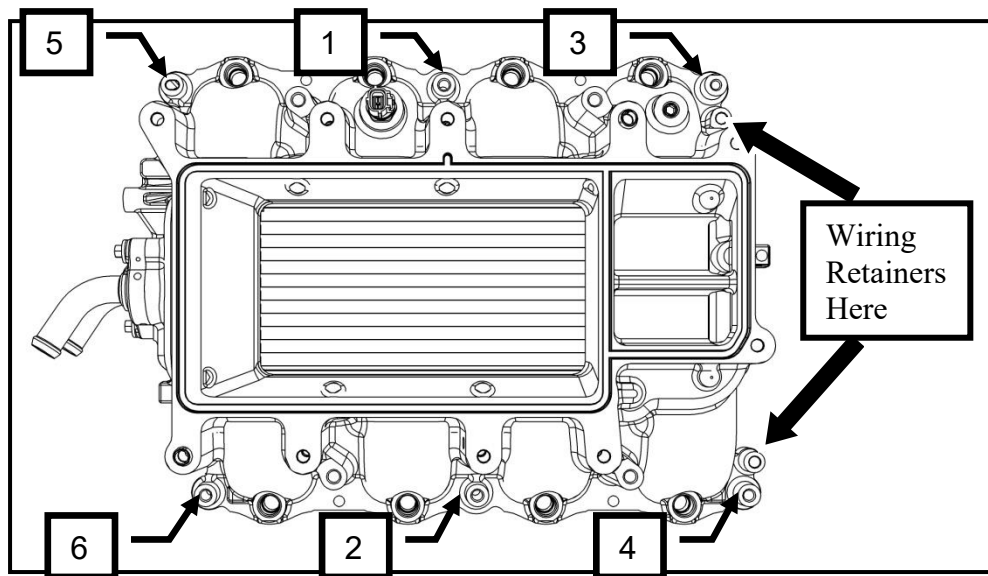

3. Lube the fuel injector o-rings with assembly lube. Install the fuel rail and injectors into the intake manifold using the take off bolts. Be sure each injector is properly seated into the intake manifold. Tighten the bolt pattern in two stages. Stage 1; torque bolts to 8-12 Nm. Stage 2; tighten bolts an additional 90 degrees.

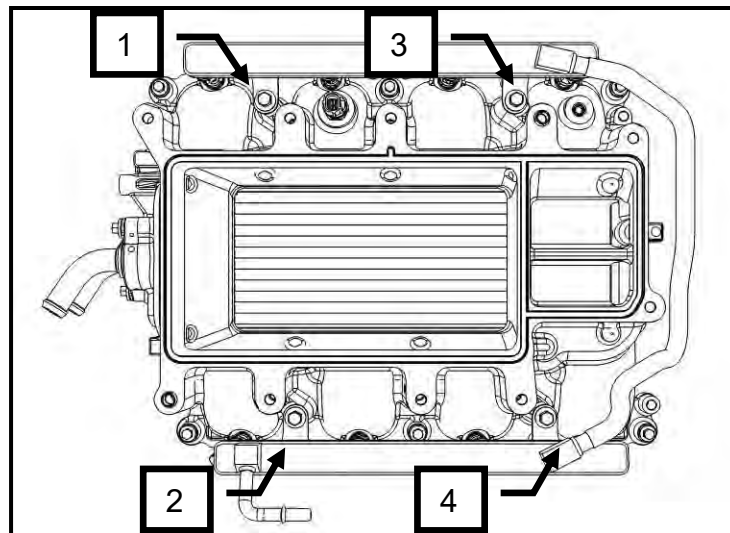



PREMIUM FUEL REQUIRED

4. Connect the eight fuel injector connectors.
5. Remove the supercharger assembly (1311H-6F066) from the protective packaging and carefully place on top of the intake manifold. Ensure that the supercharger is fully seated on the intake mounting dowels. Remove protective shipping covers.
6. Install the 85mm supercharger pulley (1313-6K85) onto the hub of the supercharger using the six (6) M6 x 16 bolts (W500013) found in Hardware Kit B (1311-TVSHKB). Apply a small amount of blue thread locking compound to each bolt and torque to 8-12 Nm.
7. Install the ten (10) M8 x 53 fasteners (N808130) provided found in Hardware Kit B (1311-TVSHKB) into the mounting holes. Torque fasteners in three steps; 10 Nm, 20 Nm and 30 Nm in the sequence shown.

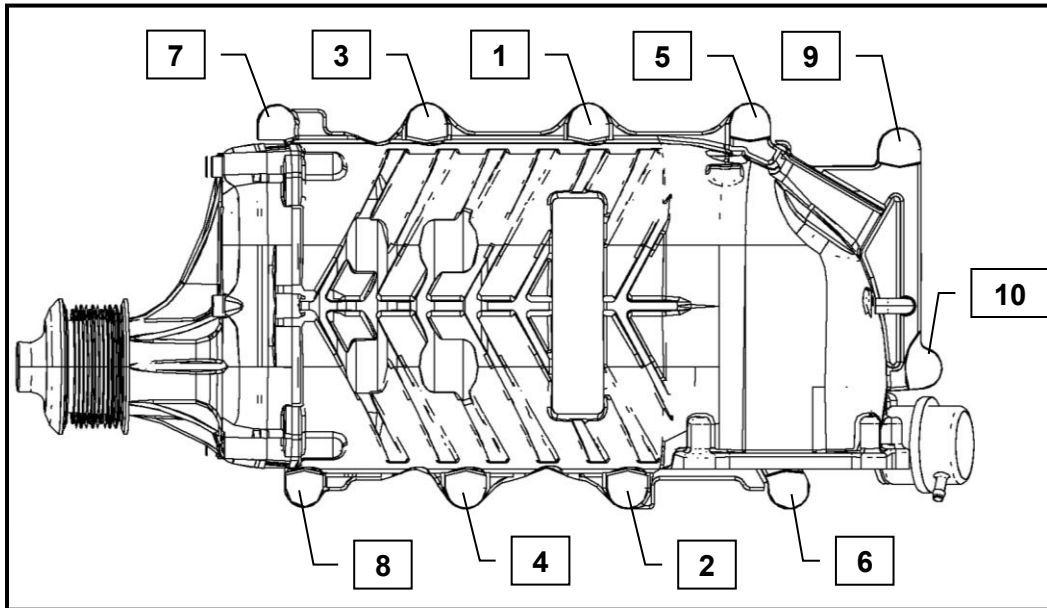



PREMIUM FUEL REQUIRED

8. Connect the supercharger bypass reference vacuum line (7R3V-9E498) to the bottom fitting on the supercharger bypass actuator. Route this underneath the heater hose and fuel line.

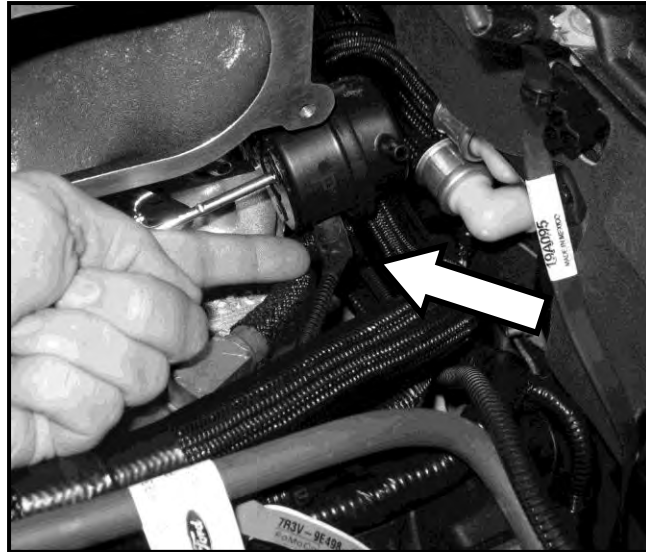

9. Install the throttle spacer to supercharger gasket (R07060152) between the throttle body spacer assembly and the supercharger and mount the spacer using (4) M6 x 32 fasteners (R18020009). These parts can be found in Hardware Kit B (1311-TVSHKB). Torque the fasteners to 8-12 Nm.

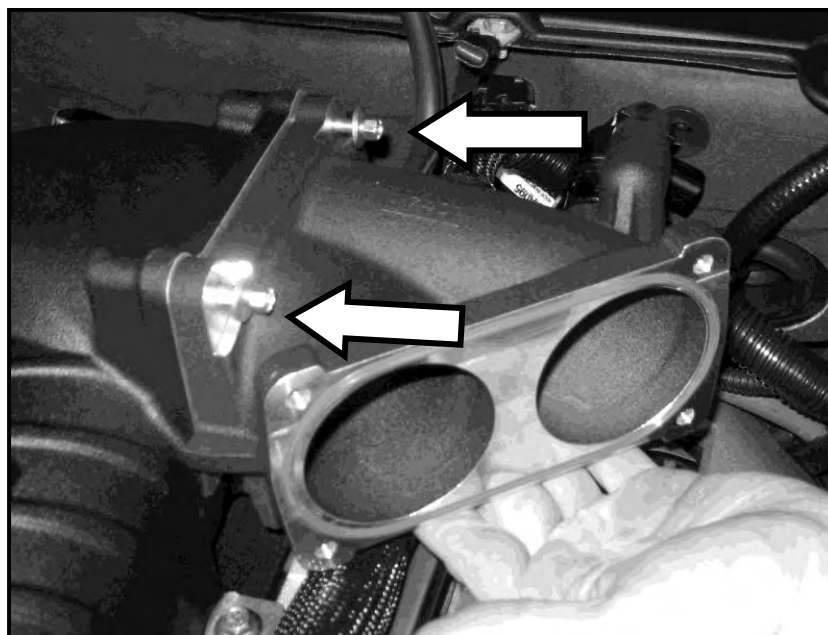



PREMIUM FUEL REQUIRED

10. Connect the boost bypass hose from the throttle body spacer to the top port of the supercharger bypass actuator.



11. **(Manual Trans Only)** Connect the brake booster vacuum line to the check valve on the brake booster.

11-a. **(Auto Trans Only)** Connect the end of hose 3 of the Brake Aspirator Assembly to the brake booster connector. Secure the connection using Clamp 5





PREMIUM FUEL REQUIRED

12. Connect the new Evaporative Emission Canister Purge Valve electrical connector.
13. Install the new Evaporative Emission Canister Purge Valve Line (BR3V-9G271) from the fitting below the brake booster to the relocated Purge Valve on the Throttle Body Spacer.

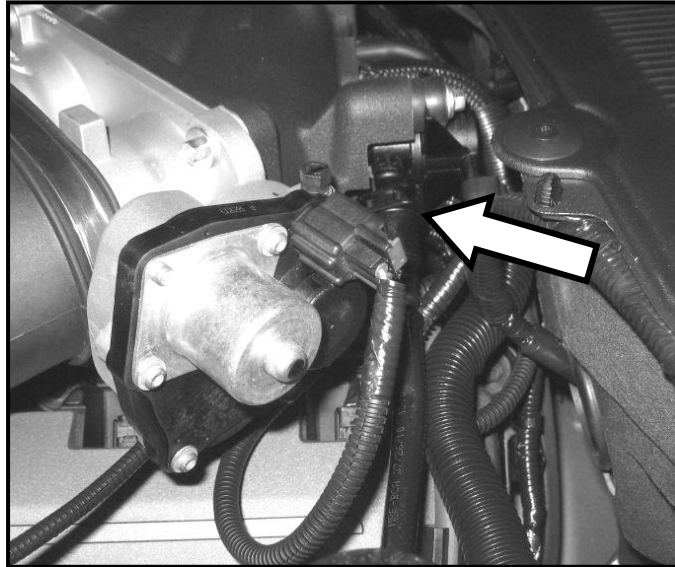

14. Connect the fuel inlet line to the fuel rail.

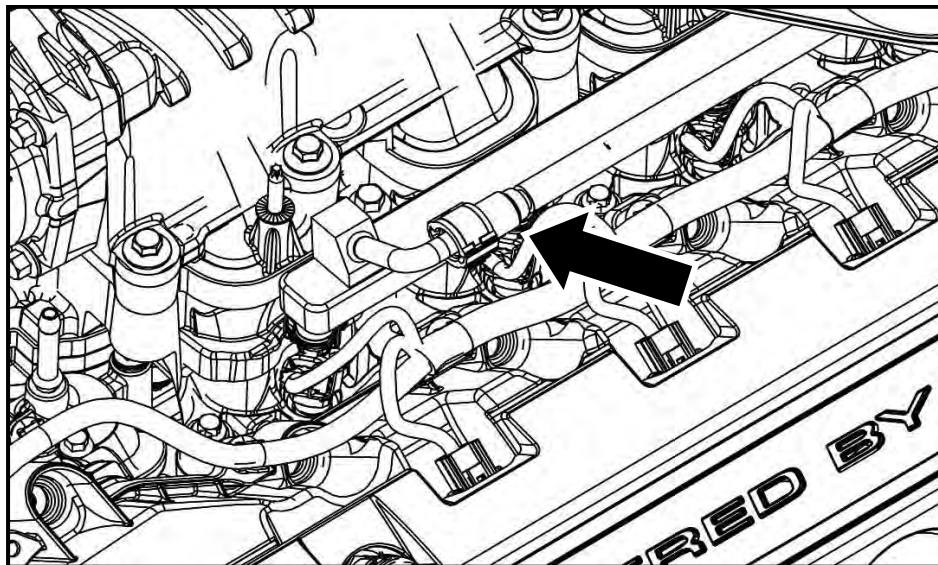



PREMIUM FUEL REQUIRED

16. Connect the PCV Purge Line (13116K817) to the PCV Valve on the passenger side cam cover and the port on the supercharger.

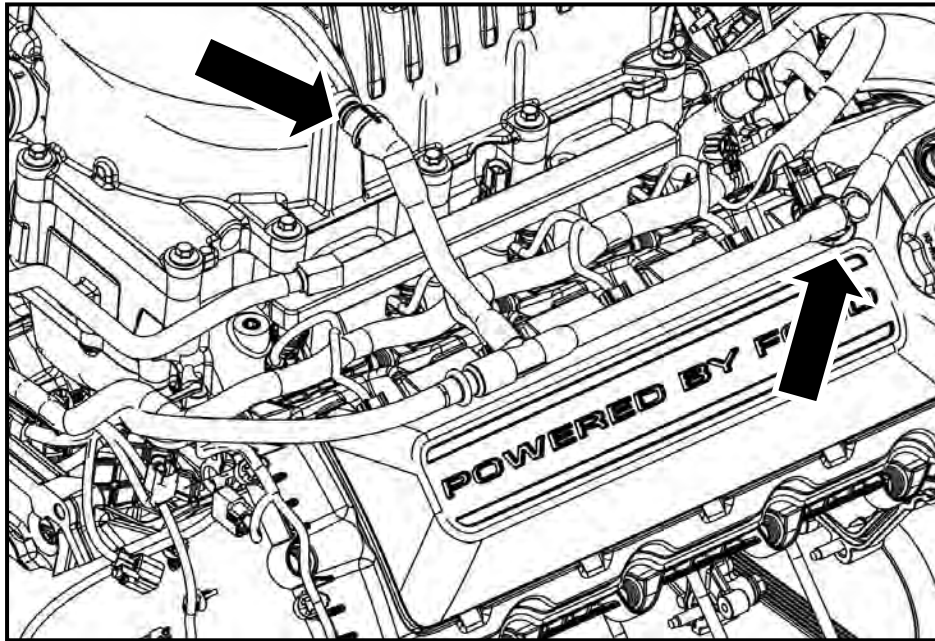

17. Install the Throttle Body Gasket (R07060153) in the Throttle Body Spacer. Use (4) M6 x 1.0 x 32.5 mm bolts (R18020009) to secure the Throttle Body Assembly (R07060150) to the Spacer. Torque bolts to 8-12 Nm. These can be found in Hardware Kit B (1311-TVSHKB).

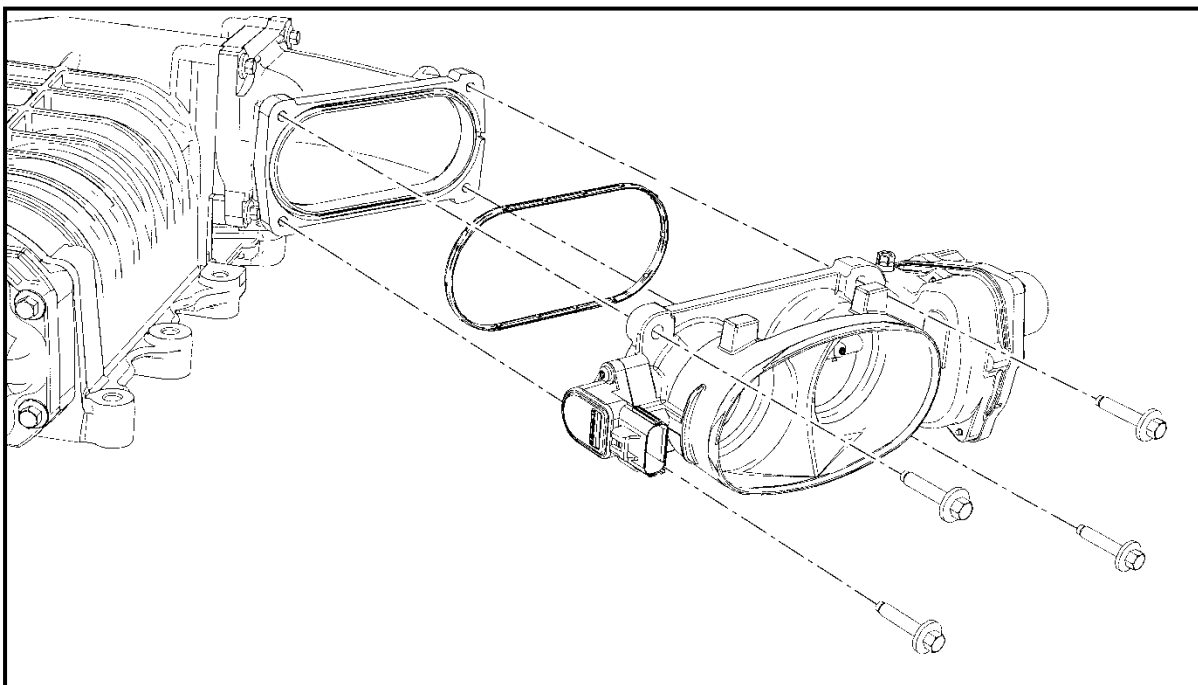



PREMIUM FUEL REQUIRED

18. Connect the TPS and ETC Throttle Body electrical connectors.

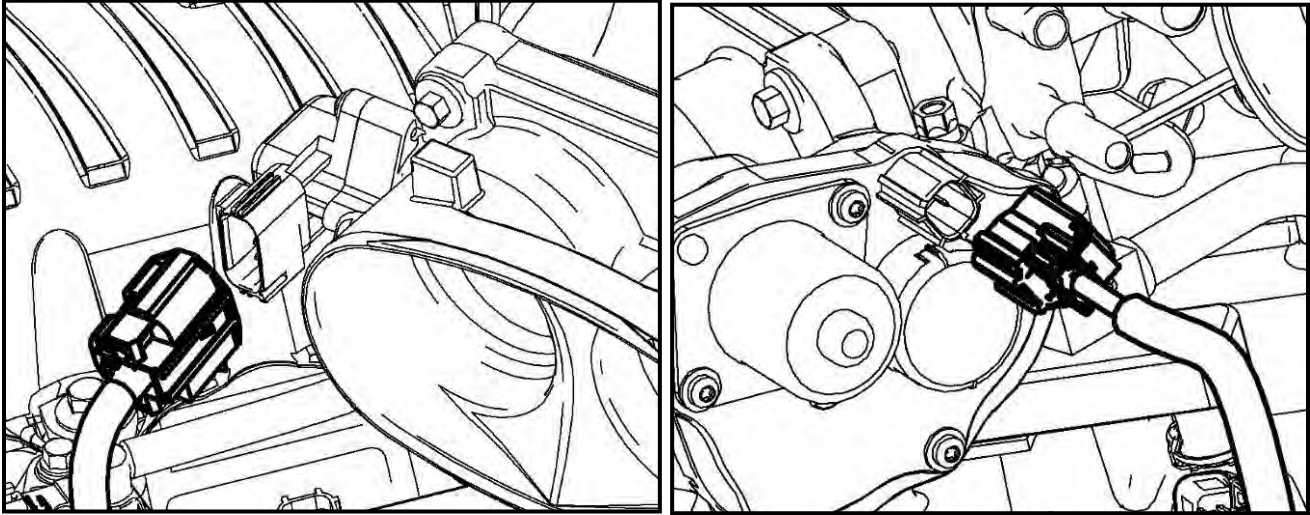



PREMIUM FUEL REQUIRED

FEAD ASSEMBLY

1. Remove the (4) bolts and (1) stud from the front cover as shown.

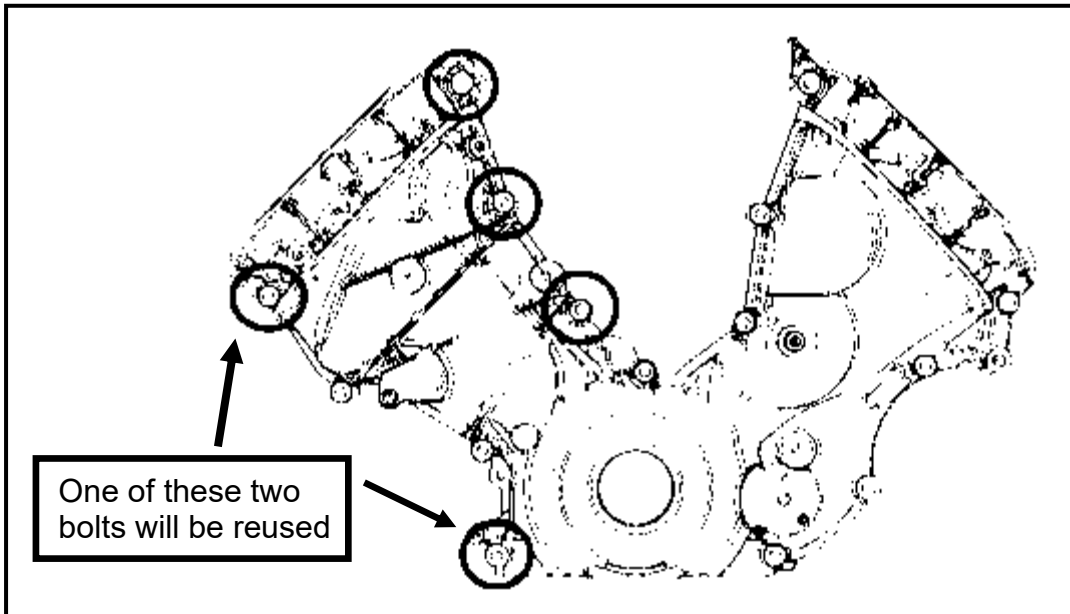

2. Remove and discard the 10mm water pump fastener shown below.

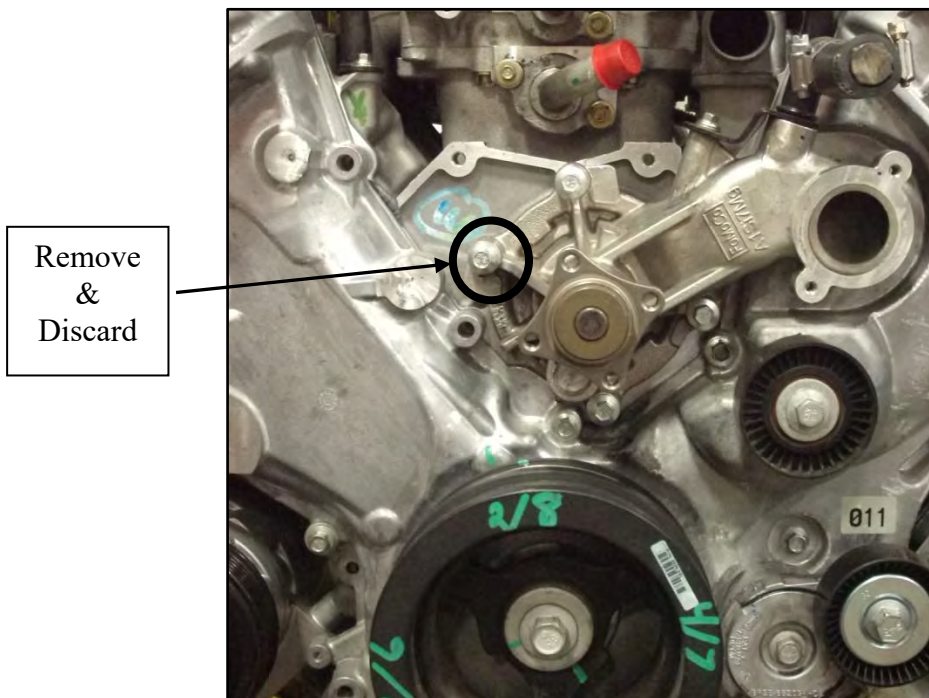



PREMIUM FUEL REQUIRED

3. Install the Upper FEAD Bracket (1314-8B653U) using one (1) M8x1.25x57 bolt that was removed in the previous step, three (3) M8x1.25x60 bolt (111116346) and two (2) M8x1.25x84 bolts (W704752) from Hardware Kit C (13116066FRTHKC). Torque bolts to 20-30 Nm.

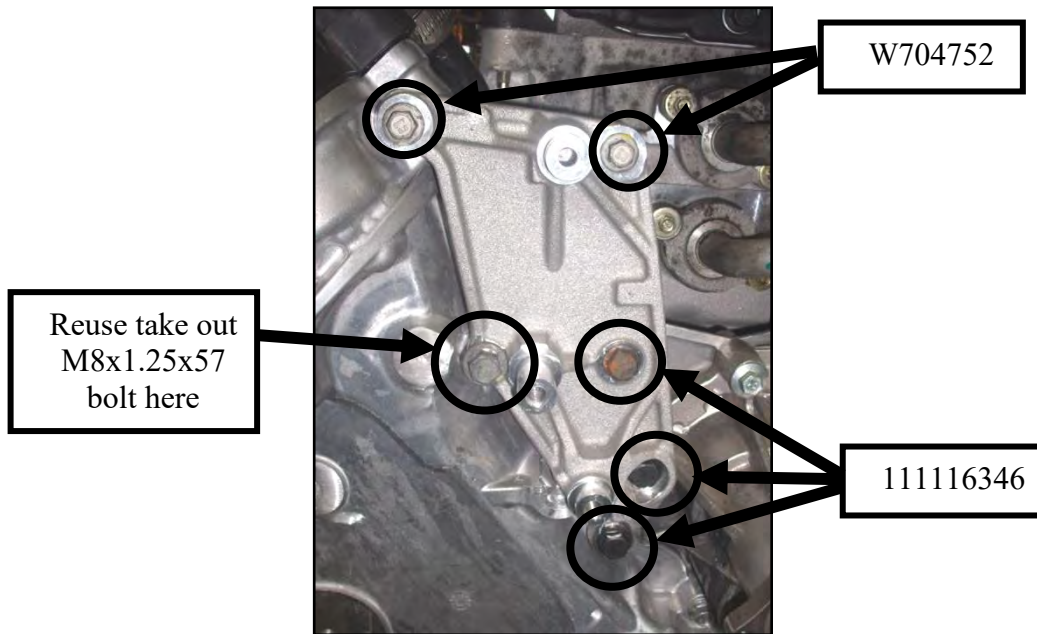

4. Install qty 1 dust shield (PT00040547) per the (2) Idler Pulleys (953045) onto the machined posts of the Upper FEAD Bracket. Secure the pulleys using (2) M8 x 1.25 x 28mm idler bolts (R18020060) found in Hardware Kit C. Torque bolts to 25 Nm. You will have one extra Dust shield for a spare in case it is damaged during installation. Be sure to center dust shield prior to torquing and test spin for no noise.

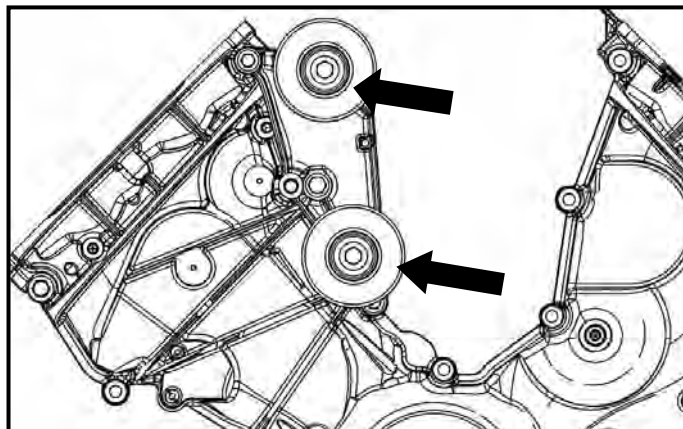



ROUSH[®]
P E R F O R M A N C E

PREMIUM FUEL REQUIRED

5. Loosely install the FEAD Tensioner Bracket Assembly (13118B603) onto the front cover using (2) M8 x 1.25 x 120mm (N811329) bolts found in Hardware Kit C, leaving at least a 10mm gap between the two new FEAD brackets.

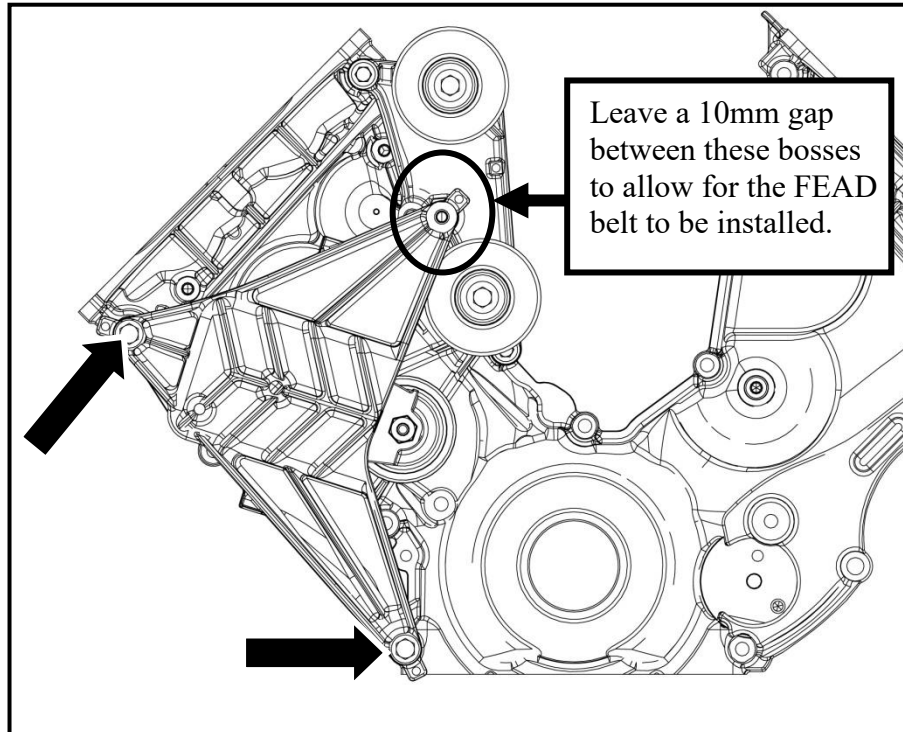



PREMIUM FUEL REQUIRED

6. Route the FEAD belt (6K2085-8620). Do not route the belt onto the supercharger pulley.

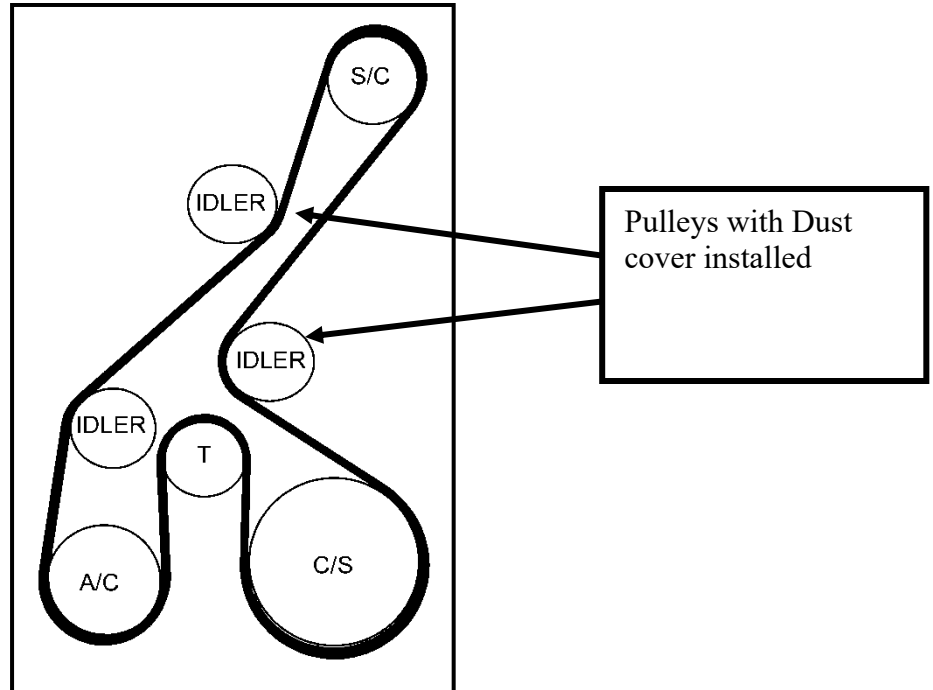

7. Install (1) M8 x 1.25 x 41mm (W705128) bolt found in Hardware Kit C, to fasten the Tensioner Bracket to the Upper FEAD Bracket. Torque all three Tensioner Bracket bolts to 20-30 Nm.

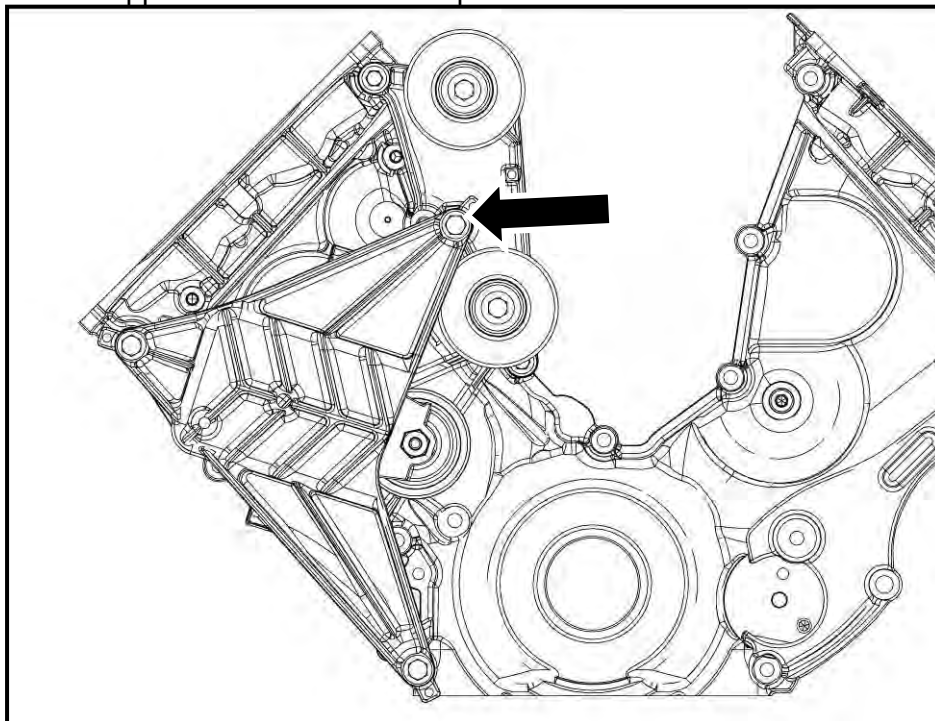



PREMIUM FUEL REQUIRED

- Using a 17mm socket, rotate the new tensioner clockwise to install the belt on to the supercharger pulley. Inspect each pulley to ensure the belt is properly seated.

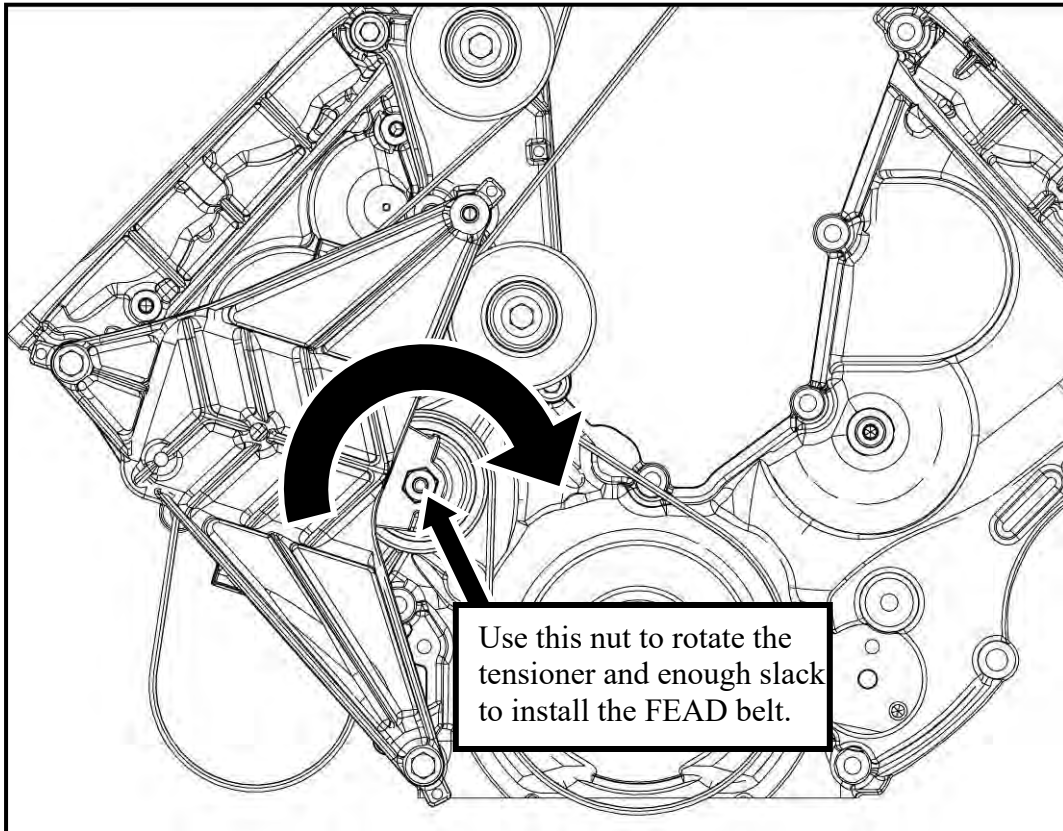

- Re-install the Coolant Pump Pulley using the (4) take off bolts. Torque bolts to 20-30 Nm.

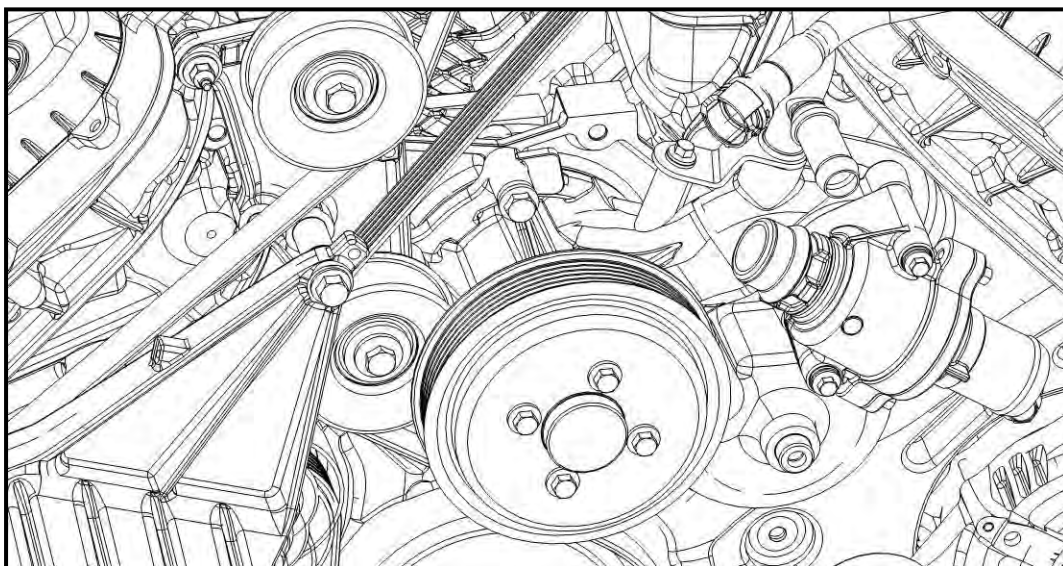



ROUSH[®]
P E R F O R M A N C E

PREMIUM FUEL REQUIRED

10. Re-install the stock FEAD Belt by rotating the tensioner counter-clockwise and routing the belt as per the stock Ford belt routing.

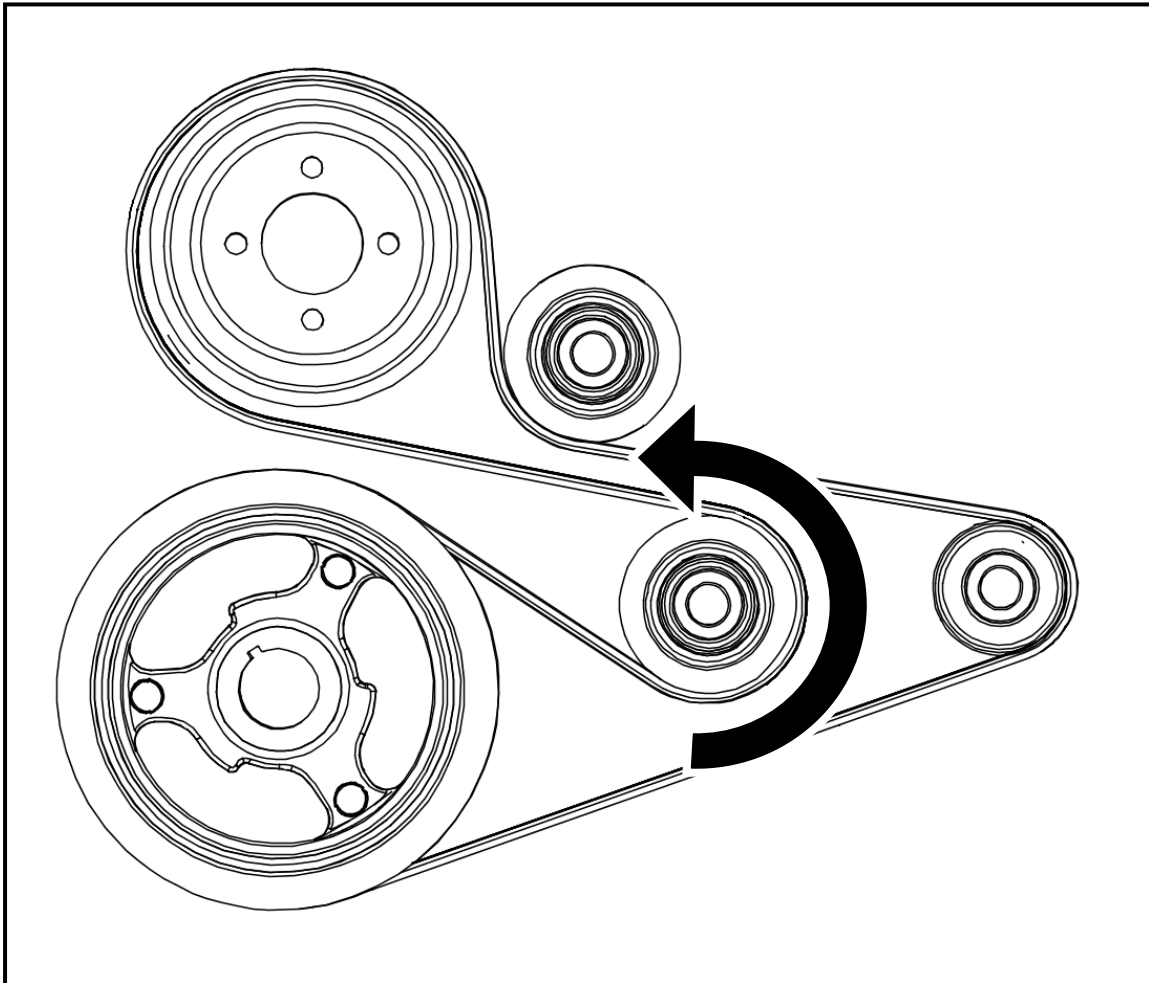



PREMIUM FUEL REQUIRED

COOLANT HOSES

1. Install the Intercooler LTR Outlet hose (13118D030). Route the hose from the LTR, behind the passenger side headlamp to the lower intercooler turret on the front of the intake manifold. Secure the hose using (2) $\frac{3}{4}$ " constant tension clamps. Orient the clamps so the "I" on the hose is in the center of the clamp tangs.

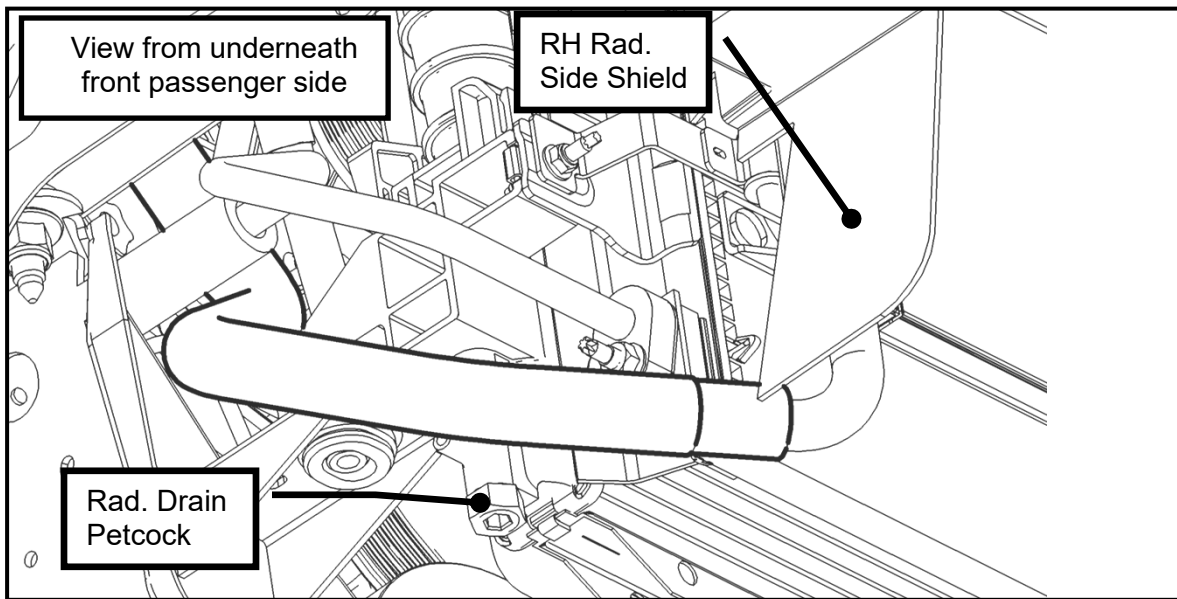

2. Install the Degas Bottle Inlet Hose (13118D031) from the upper intercooler turret to the upper degas bottle fitting using (2) $\frac{3}{4}$ " constant tension clamps. Orient the clamps so the "I" on the hose is in the center of the clamp tangs.

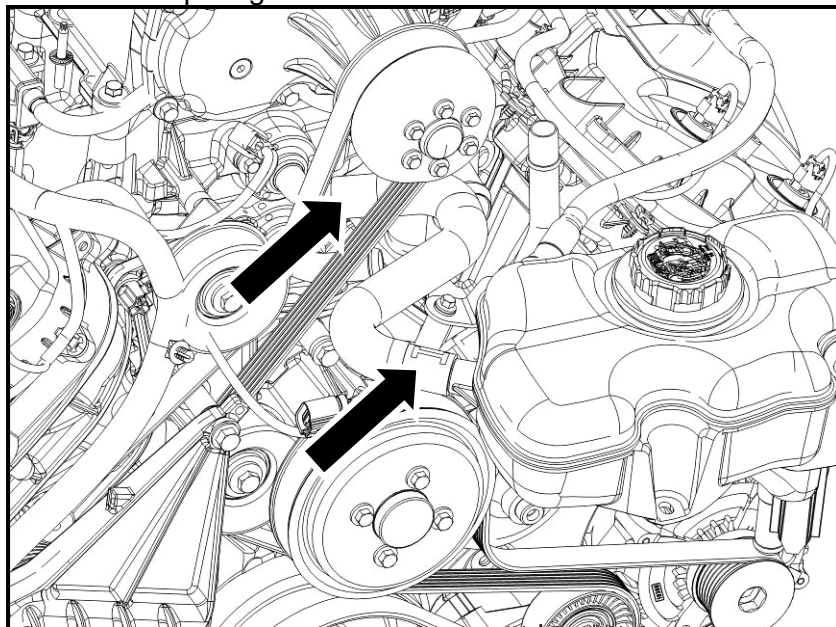



PREMIUM FUEL REQUIRED

3. Reinstall the upper radiator hose.
4. Reinstall the factory degas bottle onto the fan shroud and torque the bolt to 8 – 12 Nm.
5. Before reinstalling the factory heater feed and return hoses you must first install the protective sleeve material supplied with this kit in the areas shown below.

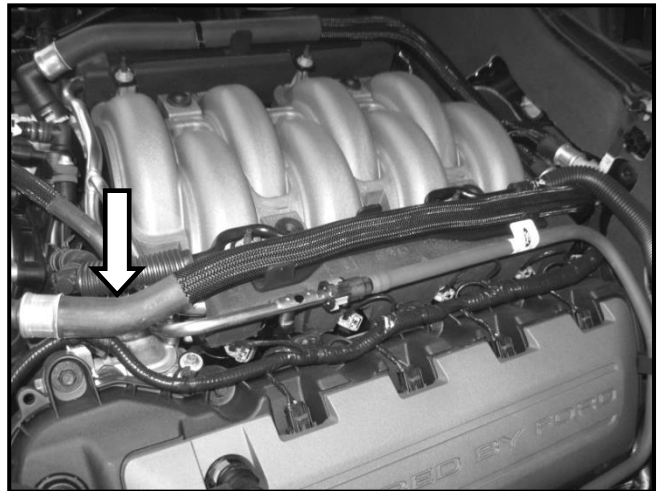
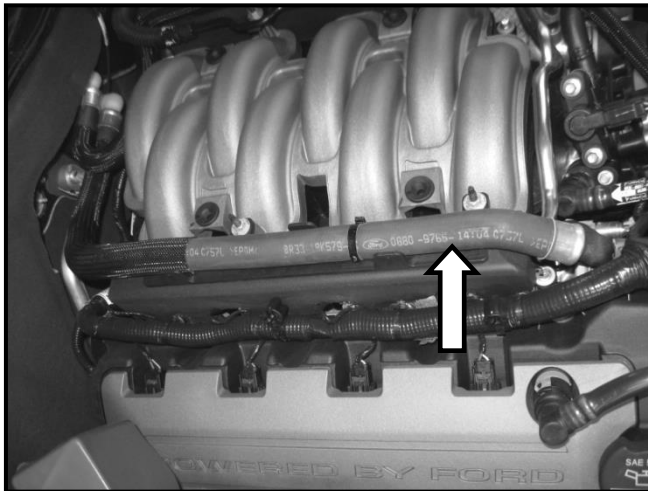

- a) Install one length of protective sleeve (1311-18K579SLV) onto the passenger side heater hose. Slide it over the quick connect fitting and along the heater hose. Apply electrical tape over either end of the protective sleeve to secure its position on the hose.





PREMIUM FUEL REQUIRED

b) Install the other length of protective sleeve (1311-18K579SLV) over the quick connect fitting and along the heater hose on the drivers side. Apply electrical tape over either end of the protective sleeve to secure its position on the hose.

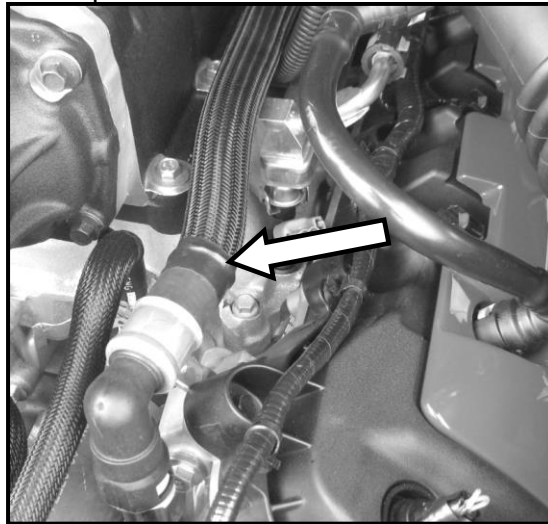

6. Install the 3/8" Engine Bottle Degas Hose (13118276) from the engine degas bottle to the fitting on the driver side cylinder head. Secure with the constant tension clamps removed from the factory hose. **Ensure both 3/4" intercooler hoses, the degas hose and all clamps and wiring have been installed to provide maximum clearance to the supercharger belt.**

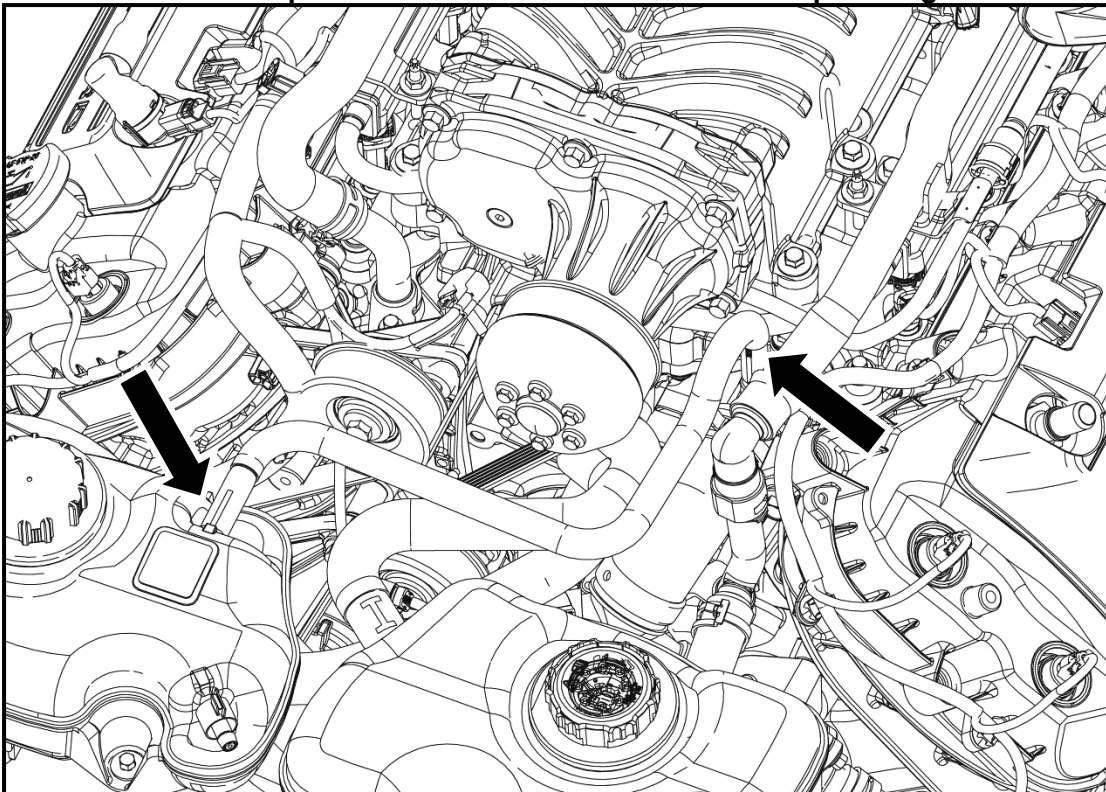



ROUSH[®]
P E R F O R M A N C E

PREMIUM FUEL REQUIRED

AIR INDUCTION SYSTEM

1. Install the 9" Edge Seal (R07130026) located on the left side of the airbox.



2. Install the 12" length of Edge Seal (R07130026) along the top edge of the airbox, overtop of the MAF Tube.



3. Install both of the 4" lengths of Edge Seal (R07130026-13) onto the edges around the bottom of the airbox.

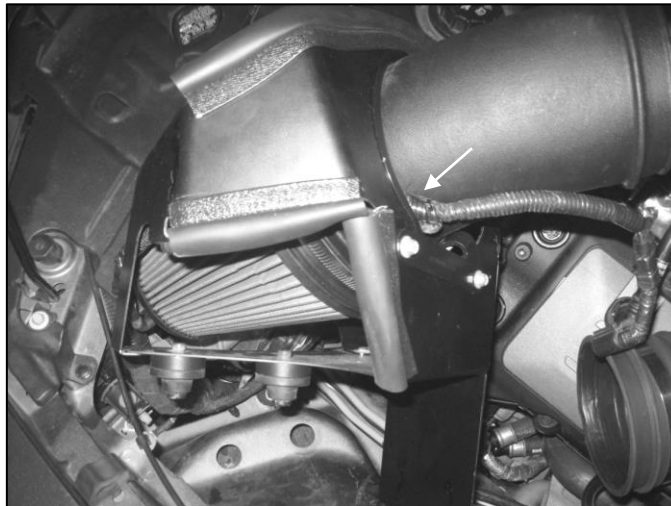



PREMIUM FUEL REQUIRED

7. Install the new airbox assembly into the vehicle. Secure the airbox to the chassis using the take off M6 bolt from the original airbox and torque to 8 – 12 Nm. Install the M6 Nut in Hardware kit over the stud for the fan shroud. Upper Lid is removed to show clarity and get better tool access.

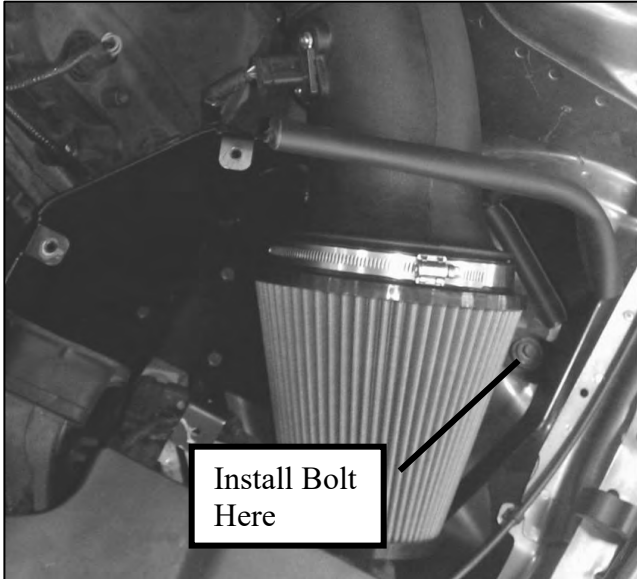

8. Install the Clean Air Tube (1313-9B659) in the vehicle using (2) hose clamps (R07130015) from Hardware Kit A. Torque clamps to 3 Nm. Install the PCV Fresh Air Inlet tube (13116758) by connecting the 90 deg fitting to the driver side cam cover and angled fitting to the PCV fitting in the clean air tube

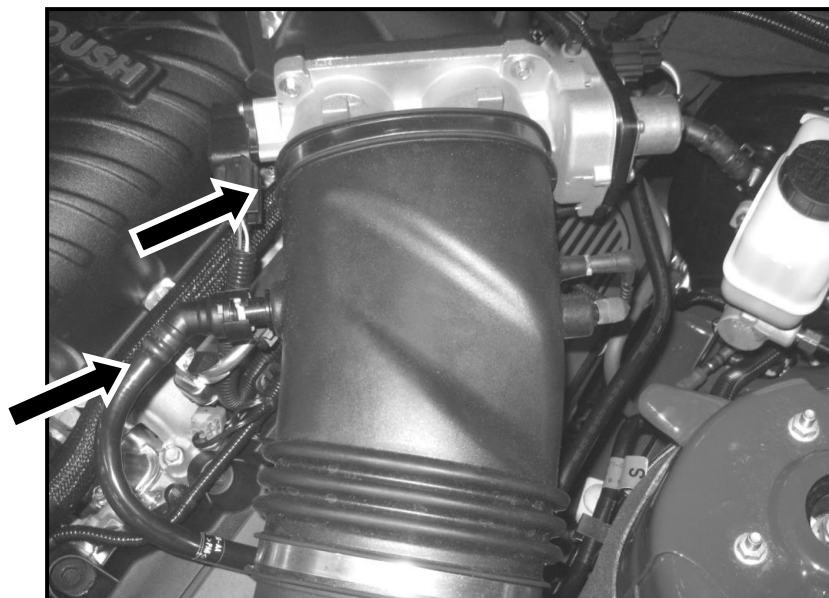



PREMIUM FUEL REQUIRED

9. Connect the open end of the supercharger bypass reference line (7R3V-9E498) to the fitting on the clean air tube.

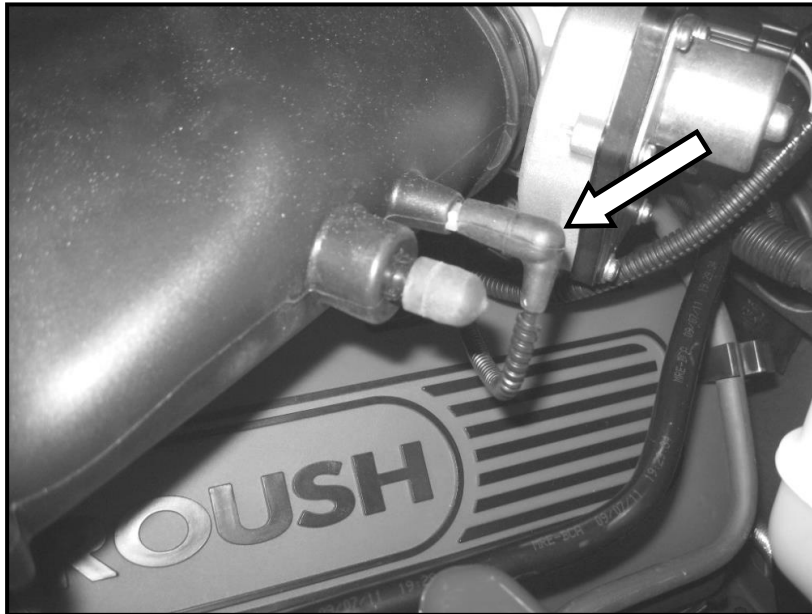

- 9-a. **(Auto Trans Only)** Connect Hose 1A of the Brake Vacuum Aspirator Assembly to the 3/8" vacuum port on the Clean Air Tube

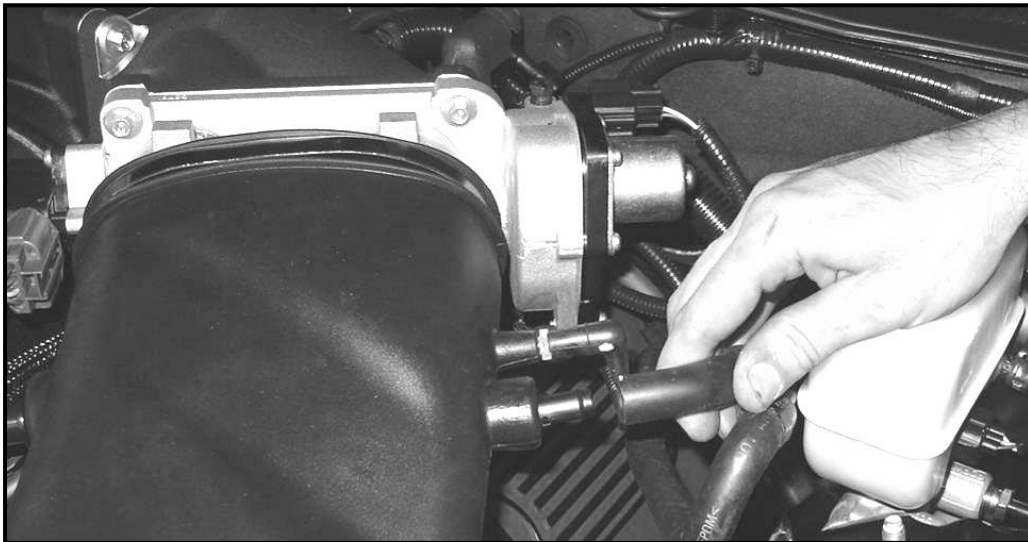



PREMIUM FUEL REQUIRED

9-b. **(Auto Trans Only)** Review the Brake Vacuum Aspirator Assembly in the vehicle to ensure there are no pinched hoses and the convolute is positioned to prevent hose abrasion from other components. Final installation should look like the image below.

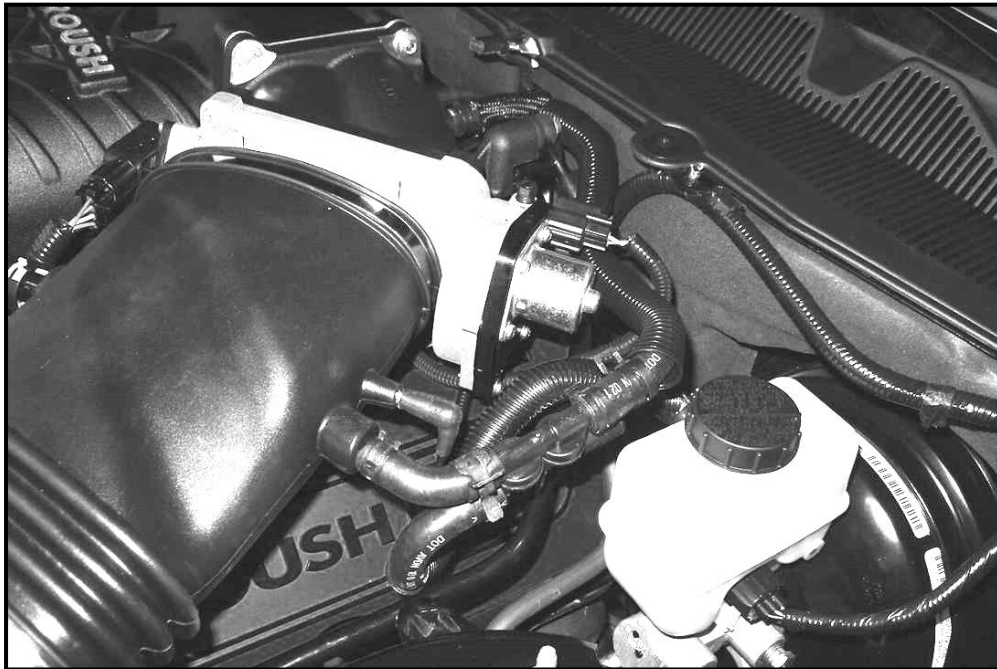

Route the MAF wire harness around the air box and connect the harness to the MAF Sensor. Make sure the red lock is engaged on the connector.





PREMIUM FUEL REQUIRED

SECTION E- FINAL ASSEMBLY

1. Fill the engine cooling system (using a proper coolant mixture) to the marked level on the radiator degas bottle.
2. Using the same coolant mixture, fill the intercooler system. The coolant should be approximately one inch below the top of the cap.

Important: Both coolant systems can trap a large amount of air. It is very important to verify that the air is purged and that coolant is flowing properly through both systems. Roush recommends vacuum filling both systems to properly evacuate the trapped air.

3. Reinstall front bumper cover, lower close-out panel and inner fenders by reversing the removal procedures.
4. Reinstall the front wheels/tires. Torque wheel lugs to the factory Ford specifications.
5. Inspect all underhood wiring harnesses for potential interference issues. Use zip ties to safely position the harness away from any areas of concern.
6. Reinstall the radiator trim cover by reversing the removal instructions.
7. If the PCM was removed and shipped to ROUSH for a ROUSH performed flash, reinstall it once the PCM is returned from ROUSH. If you are equipped with a SAE J2534 pass through device, refer to the PCM Flashing section when installation is complete. **DO NOT ATTEMPT TO REINSTALL THE PCM AND START THE VEHICLE IF THE PCM IS NOT EQUIPPED WITH A ROUSH CALIBRATION. OPERATING THE ENGINE WITHOUT THE RECALIBRATED PCM WILL RESULT IN ENGINE DAMAGE OR FAILURE AND WILL VOID THE WARRANTY.**
8. Reinstall the battery connections by connecting the positive cable first then connecting the negative cable.
9. Reconnect the fuel pump control module electrical connector located in the spare tire stowage compartment.



PREMIUM FUEL REQUIRED

10. The Belt Routing Diagram (13116E072) is to be placed on the underside of the hood, on the driver side, opposite of the factory Vehicle Emission Control Information decal.

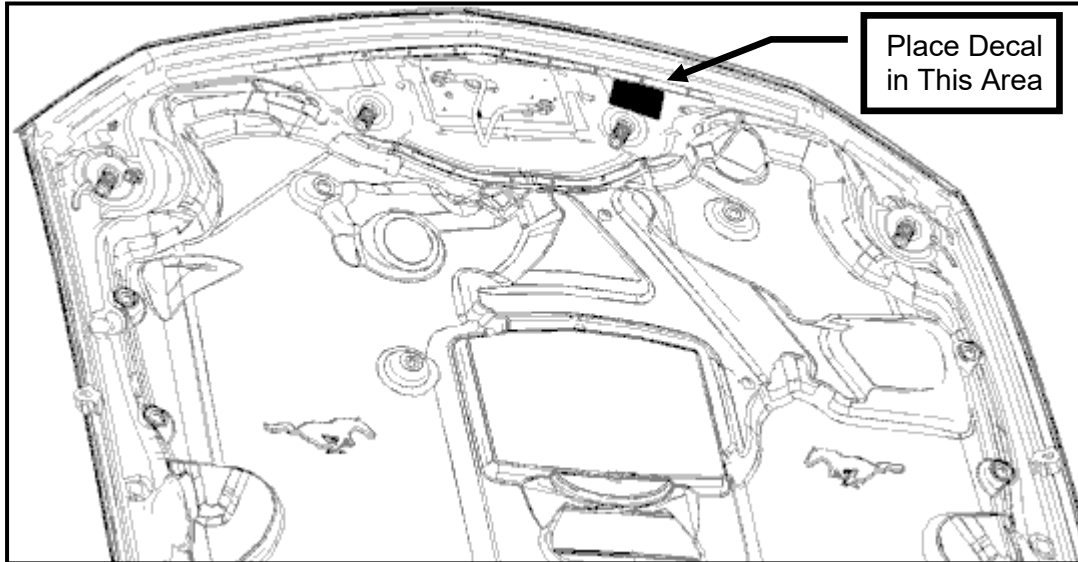

11. Place the EO Label (D41822-9A095EO) under hood in a visible location (on the bottom side of the hood or on the strut tower).

12. Place the "Premium Fuel" (13109A095) white decal with black lettering on the arm door of the fuel filler door as shown.

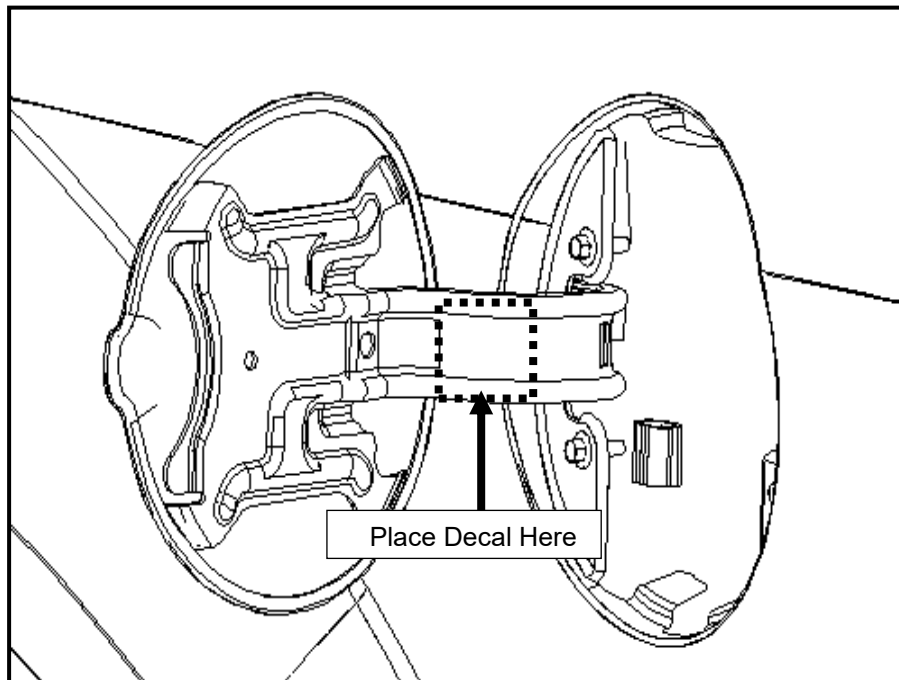



PREMIUM FUEL REQUIRED

13. Place the “Premium Fuel” (R07110004) clear decal with white lettering on the instrument cluster bezel, on the flat area below the small center gauges as shown.

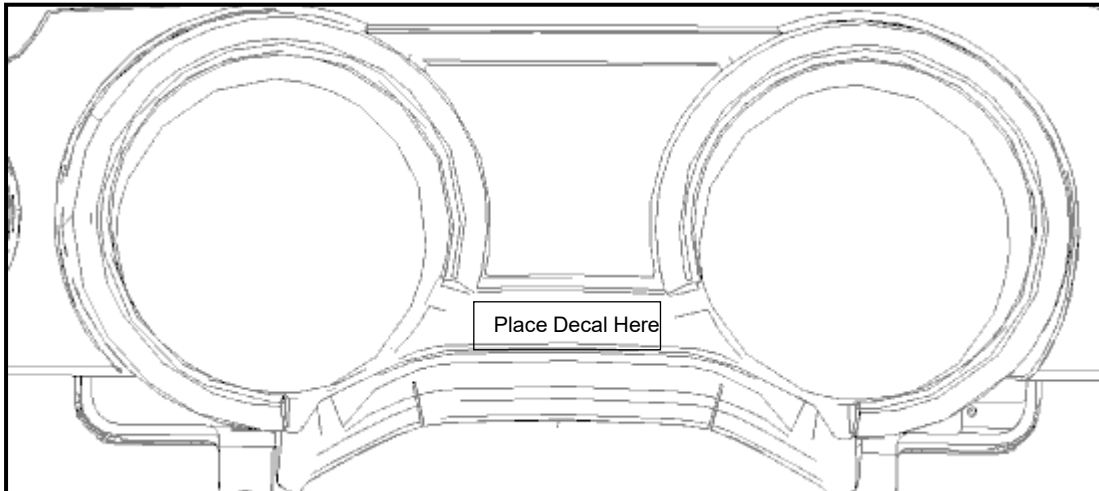

14. **If performing the PCM Flash procedure, proceed to the “PCM Flashing” section. If the PCM was sent to ROUSH for the Optional ROUSH Performed Flash and it has been reinstalled,** start the engine and check for unusual noise, dash service lights, and/or unusual operation. If problems are detected, immediately stop the engine or vehicle, diagnose and repair the problem.



PREMIUM FUEL REQUIRED

PCM FLASHING

1. If equipped with a SAE J2534 pass through device, refer to the RDT-CALIM manual included in the CALKIT for PCM flashing. The RDT-CALIM manual will guide you through the ROUSH Diagnostic Tool (RDT) software installation process and the ROUSH PCM flashing procedure. **OPERATING THE ENGINE WITHOUT THE RECALIBRATED PCM WILL RESULT IN ENGINE DAMAGE OR FAILURE AND WILL VOID THE WARRANTY.**

RDT-CALIM manual: https://roush.my.salesforce.com/sfc/p/#80000000PSJg/a/Ue000000IOQT/JHUCFJ0rSqh1W_0_0ft_YzcSCGeodUIR87oa_Wp0an8

2. Once the PCM has been successfully re-calibrated, start the engine and check for unusual noises, dash service lights, and unusual operation. If problems are detected, immediately stop the engine or vehicle, diagnose and repair the problem.

APPENDIX A – SIDE SHIELD MODIFICATIONS

- 1 - Remove the LH radiator side shield from the vehicle by removing the two push pin retainers.

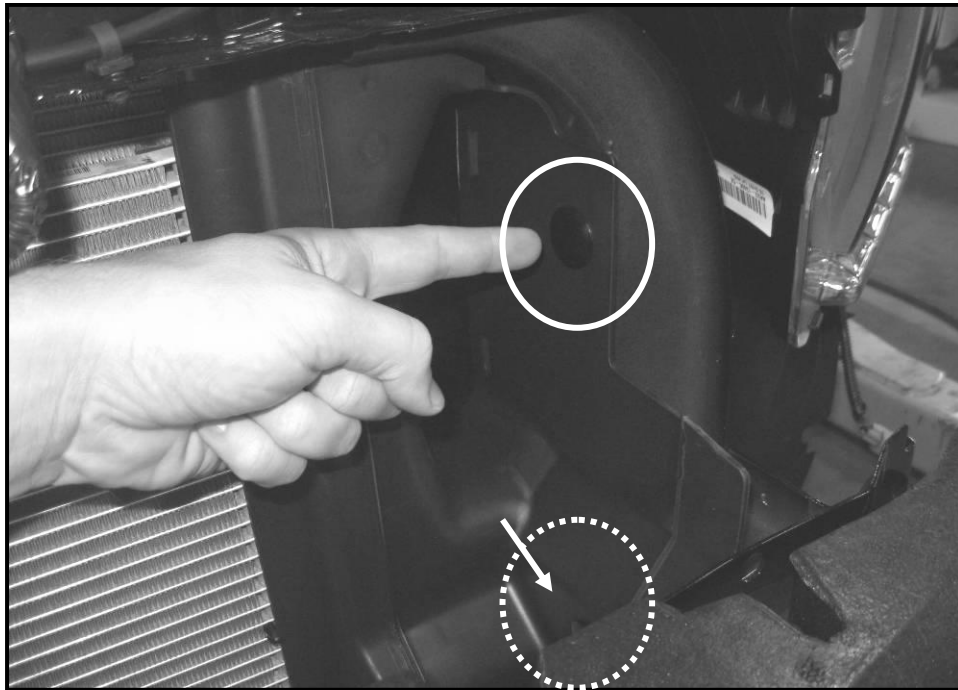



ROUSH
P E R F O R M A N C E

PREMIUM FUEL REQUIRED

- 2 - Cut the rubber edge of the side shield in three (3) places as shown.

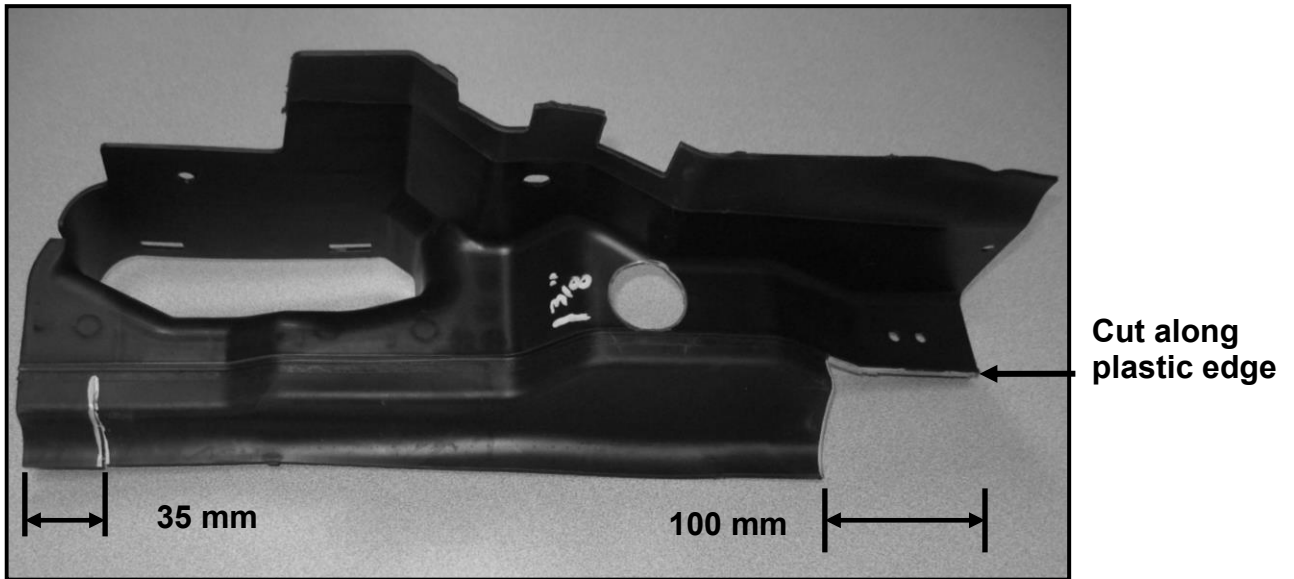

- 3 - Using a hole saw, drill a 1 3/8" hole through the plastic portion of the shield 180mm from the end as shown.

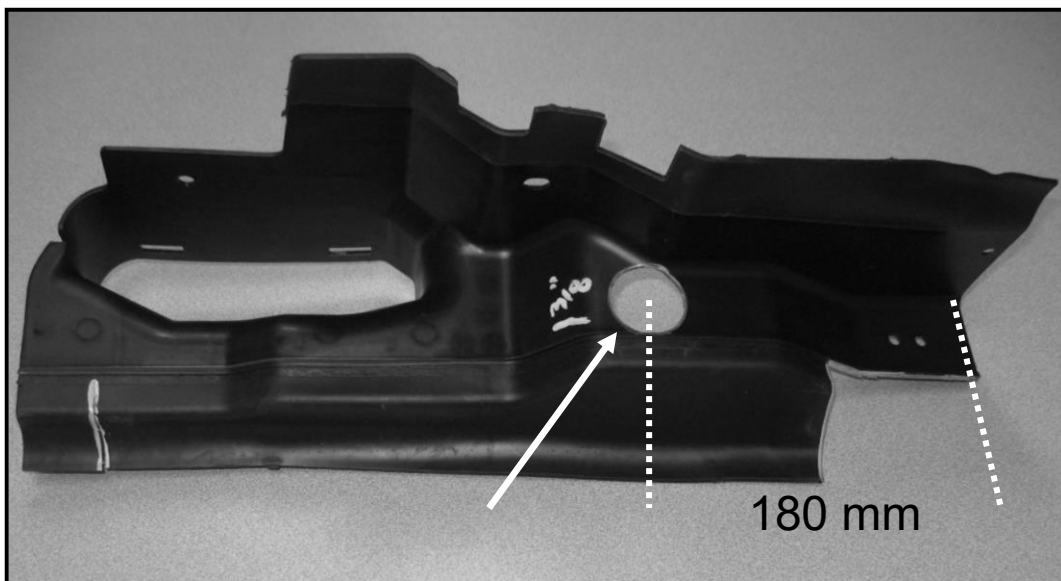

- 4 - Re-install the LH radiator side shield using the take off push pins.



PREMIUM FUEL REQUIRED

- 5 - Remove the RH radiator side shield from the vehicle by removing the two push pins.

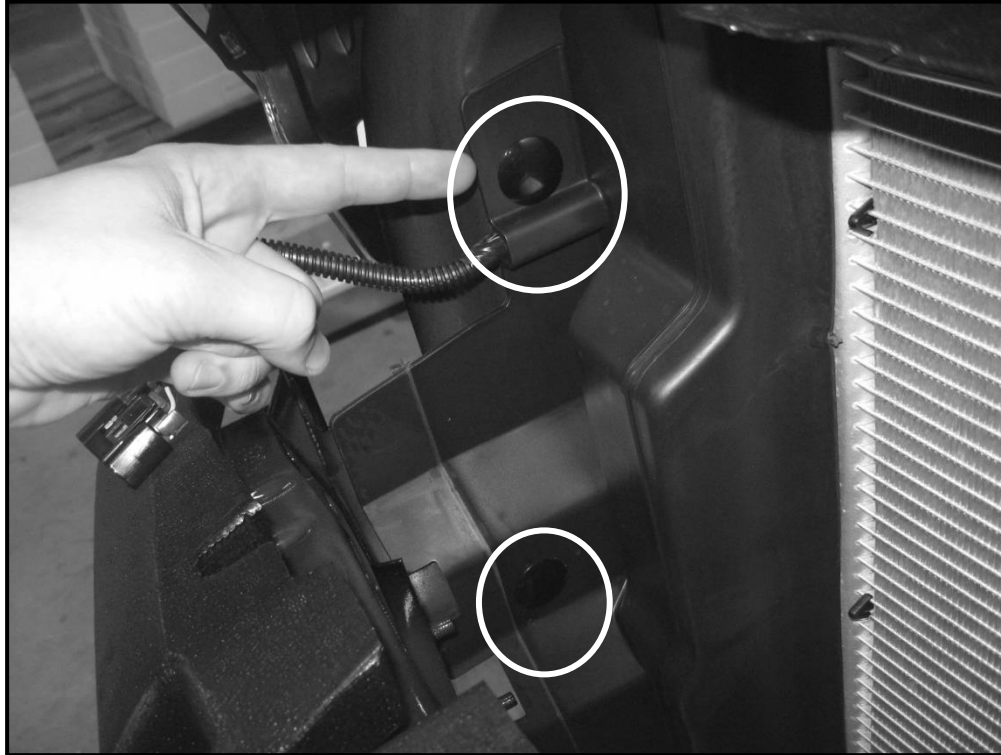

- 6 - Cut the rubber edge of the side shield in three (3) places as shown.

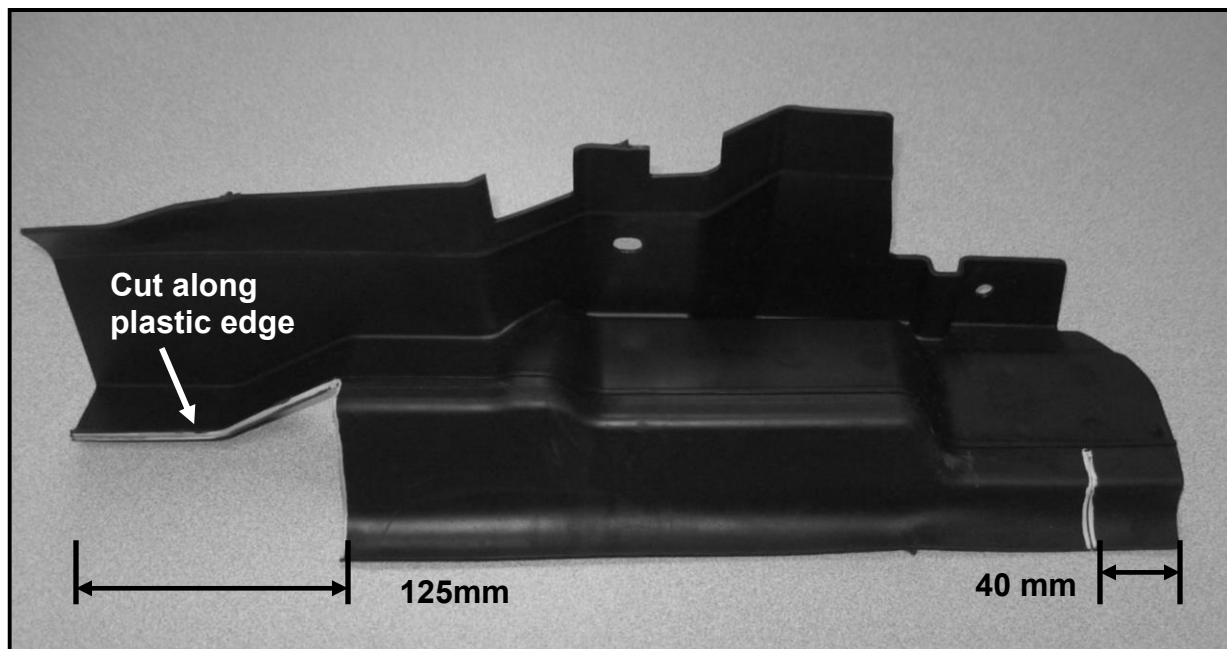

- 7 - Re-install the RH radiator side shield using the take off push pins.